

МИНИСТЕРСТВО ОБРАЗОВАНИЯ РЕСПУБЛИКИ БЕЛАРУСЬ
УЧРЕЖДЕНИЕ ОБРАЗОВАНИЯ
«БРЕСТСКИЙ ГОСУДАРСТВЕННЫЙ ТЕХНИЧЕСКИЙ УНИВЕРСИТЕТ»
КАФЕДРА ВЫСШЕЙ МАТЕМАТИКИ

ELEMENTS OF THEORY OF ANALYTIC FUNCTIONS OF ONE COMPLEX VARIABLE

учебно-методическая разработка на английском языке
по дисциплине «Математика»

Брест 2015

УДК 517.53 (076)=111

Настоящая методическая разработка предназначена для иностранных студентов технических специальностей. Данная разработка содержит необходимый материал по теме «Теория функций комплексной переменной». Изложение теоретического материала сопровождается рассмотрением большого количества примеров и задач, некоторые понятия и примеры проиллюстрированы.

Составители: Гладкий И.И., доцент

Дворниченко А.В., старший преподаватель

Каримова Т.И., к.ф.-м.н., доцент

Лебедь С.Ф., к.ф.-м.н., доцент

Шишко Т.В., преподаватель кафедры иностранных языков по техническим специальностям

Рецензент: Мирская Е.И., доцент кафедры алгебры, геометрии и математического моделирования учреждения образования «Брестский государственный университет им. А.С. Пушкина», к.ф.-м.н., доцент.

1 Complex Number System

1.1 The Complex Number System. Fundamental Operations with Complex Numbers

There is no real number x that satisfies the polynomial equation $x^2 + 1 = 0$. To permit solutions of this and similar equations, the set of complex numbers is introduced.

We can consider a complex number as having the form $a + ib$ where a and b are real numbers and i , which is called the imaginary unit, has the property that $i^2 = -1$. If $z = a + ib$, then a is called the real part of z and b is called the imaginary part of z and are denoted by $\text{Re}\{z\}$ and $\text{Im}\{z\}$, respectively. The symbol z , which can stand for any complex number, is called a complex variable.

Two complex numbers $a + ib$ and $c + di$ are equal if and only if $a = c$ and $b = d$. We can consider real numbers as a subset of the set of complex numbers with $b = 0$. Accordingly the complex numbers $0 + 0i$ and $-3 + 0i$ represent the real numbers 0 and -3 , respectively. If $a = 0$, the complex number $0 + bi$ or bi is called a pure imaginary number.

The complex conjugate, or briefly conjugate, of a complex number $a + ib$ is $a - ib$. The complex conjugate of a complex number z is often indicated by \bar{z} or z^* .

In performing operations with complex numbers, we can proceed as in the algebra of real numbers, replacing i^2 by -1 when it occurs.

(1) Addition

$$(a + bi) + (c + di) = a + bi + c + di = (a + c) + (b + d)i.$$

(2) Subtraction

$$(a + bi) - (c + di) = a + bi - c - di = (a - c) + (b - d)i.$$

(3) Multiplication

$$(a + bi) \cdot (c + di) = ac + cbi + bdi^2 + adi = (ac - bd) + (ad + bc)i.$$

(4) Division

$$\frac{a + bi}{c + di} = \frac{a + bi}{c + di} \cdot \frac{c - di}{c - di} = \frac{ac + bd + (bc - ad)i}{c^2 + d^2} = \frac{ac + bd}{c^2 + d^2} + \frac{bc - ad}{c^2 + d^2}i.$$

The absolute value or modulus of a complex number $a + ib$ is defined as $|a + bi| = \sqrt{a^2 + b^2}$.

Example 1 $|-4 + 2i| = \sqrt{(-4)^2 + 2^2} = \sqrt{20} = 2\sqrt{5}$.

Suppose real scales are chosen on two mutually perpendicular axes $X'OX$ and $Y'OY$ [called the x and y axes, respectively] as in Fig.1. We can locate any point in the plane determined by these lines by the ordered pair of real numbers (x, y) called rectangular coordinates of the point. Examples of the location of such points are indicated by P, Q, R, S , and T in Fig.1.

Since a complex number $x + iy$ can be considered as an ordered pair of real numbers, we can represent such numbers by points in an xy plane called the complex plane or Argand diagram. The complex number represented by P , for example, could then be read as either $(3, 4)$ or $3 + 4i$. To each complex number there corresponds one and only one point in the plane, and conversely to each point in the plane there corresponds one and only one complex number. Because of this we often refer to the complex number z as the point z . Sometimes, we refer to

the x and y axes as the real and imaginary axes, respectively, and to the complex plane as the z plane. The distance between two points, $z_1 = x_1 + iy_1$ and $z_2 = x_2 + iy_2$, in the complex plane is given by $|z_1 - z_2| = \sqrt{(x_1 - x_2)^2 + (y_1 - y_2)^2}$.

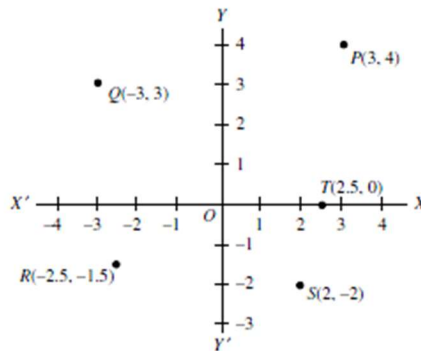

Fig.1

1.2 Graphical Representation of Complex Numbers. Polar Form of Complex Numbers

Let P be a point in the complex plane corresponding to the complex number (x, y) or $x + iy$. Then we see from Fig.2 that $x = r \cos \varphi, y = r \sin \varphi$, where $r = \sqrt{x^2 + y^2} = |x + iy|$ is called the modulus or absolute value of $z = x + iy$ [denoted by $\text{mod } z$ or $|z|$] and φ , called the amplitude or argument of $z = x + iy$ [denoted by $\text{arg } z$], is the angle that line OP makes with the positive x axis.

It follows that

$$z = x + iy = r(\cos \varphi + i \sin \varphi) \quad (1)$$

which is called the polar form of the complex number, and r and φ are called polar coordinates.

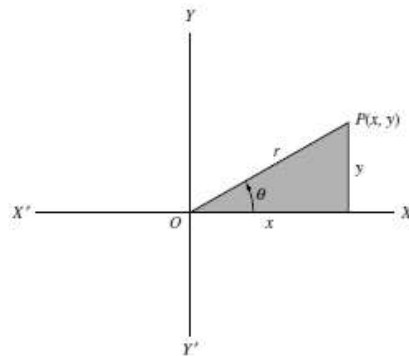

Fig.2

For any complex number $z \neq 0$ there corresponds only one value of φ in $0 \leq \varphi < 2\pi$. However, any other interval of length 2π , for example $-\pi \leq \varphi < \pi$, can be used. Any particular choice, decided upon in advance, is called the principal range, and the value of φ is called its principal value.

Let $z_1 = x_1 + iy_1 = r_1(\cos \varphi_1 + i \sin \varphi_1)$ and $z_2 = x_2 + iy_2 = r_2(\cos \varphi_2 + i \sin \varphi_2)$, then we can show that

$$z_1 z_2 = r_1 r_2 (\cos(\varphi_1 + \varphi_2) + i \sin(\varphi_1 + \varphi_2)) \quad (2)$$

$$\frac{z_1}{z_2} = \frac{r_1}{r_2} (\cos(\varphi_1 - \varphi_2) + i \sin(\varphi_1 - \varphi_2)) \quad (3)$$

A generalization of (2) leads to

$$z_1 z_2 \cdots z_n = r_1 r_2 \cdots r_n (\cos(\varphi_1 + \varphi_2 + \dots + \varphi_n) + i \sin(\varphi_1 + \varphi_2 + \dots + \varphi_n)) \quad (4)$$

and if $z_1 = \dots = z_n = z$ this becomes

$$z^n = r^n (\cos n\varphi + i \sin n\varphi) \quad (5)$$

which is often called De Moivre's theorem.

1.3 Euler's Formula. Polynomial Equations. Roots of Complex Numbers

A number w is called an n -th root of a complex number z if $w^n = z$, and we write $w = z^{\frac{1}{n}}$. From

De Moivre's theorem we can show that if n is a positive integer,

$$z^{\frac{1}{n}} = r^{\frac{1}{n}} \left(\cos \left(\frac{\varphi + 2k\pi}{n} \right) + i \sin \left(\frac{\varphi + 2k\pi}{n} \right) \right), k = 0, 1, 2, \dots, n-1 \quad (6)$$

from which it follows that there are n different values for $z^{\frac{1}{n}}$, i.e., n different n -th roots of z , provided $z \neq 0$.

By assuming that the infinite series expansion $e^x = 1 + x + \frac{x^2}{2!} + \frac{x^3}{3!} + \dots$ of elementary calculus holds when $x = i\varphi$, we can arrive at the result

$$e^{i\varphi} = \cos \varphi + i \sin \varphi \quad (7)$$

which is called Euler's formula. It is more convenient, however, simply to take (7) as a definition of $e^{i\varphi}$. In general, we define

$$e^z = e^{x+iy} = e^x (\cos y + i \sin y) \quad (8)$$

Let P [Fig.3] be the complex plane and consider a sphere \underline{S} tangent to P at $z = 0$. The diameter NS is perpendicular to P and we call points N and S the north and south poles of \underline{S} . Corresponding to any point A on P we can construct line NA intersecting \underline{S} at point A' . Thus to each point of the complex plane P there corresponds one and only one point of the sphere \underline{S} , and we can represent any complex number by a point on the sphere. For completeness we say that the point N itself corresponds to the "point at infinity" of the plane. The set of all points of the complex plane including the point at infinity is called the entire complex plane, the entire z plane, or the extended complex plane.

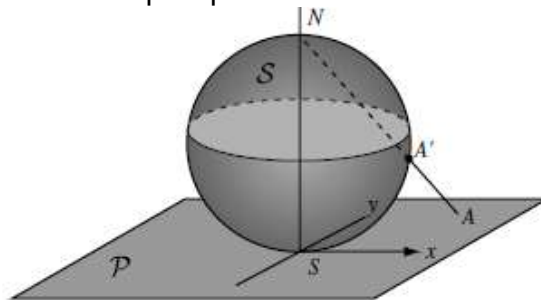

Fig.3

The above method for mapping the plane on to the sphere is called stereographic projection. The sphere is sometimes called the Riemann sphere. When the diameter of the Riemann sphere is chosen to be unity, the equator corresponds to the unit circle of the complex plane.

Example 2 Perform each of the indicated operations.

Solution

(a) $(3 + 2i) + (6 - 7i) = 3 + 6 + 2i - 7i = 9 - 5i.$

(b) $(-4 - 3i) - (5 - 7i) = -4 - 5 - 3i + 7i = -9 + 4i.$

(c) $(2 - 3i) \cdot (5 + 2i) = 2 \cdot 5 + 2 \cdot 2i - 5 \cdot 3i - 3 \cdot 2i^2 = 10 + 6 + 4i - 15i = 16 - 11i.$

(d) $\frac{3 - 2i}{1 + 6i} = \frac{3 - 2i}{1 + 6i} \cdot \frac{1 - 6i}{1 - 6i} = \frac{3 - 2i - 18i + 12i^2}{1 - 36i^2} = \frac{-9 - 20i}{37} = -\frac{9}{37} - \frac{20}{37}i.$

Example 3 Suppose, $z_1 = 2 + i$, $z_2 = 3 - 2i$. Evaluate each of the following.

Solution

(a) $|3z_1 - 4z_2| = |3(2 + i) - 4(3 - 2i)| = |-6 + 11i| = \sqrt{(-6)^2 + 11^2} = \sqrt{157}.$

(b) $z_1^3 - 3z_1^2 + 4z_1 - 8 = (2 + i)^3 - 3(2 + i)^2 + 4(2 + i) - 8 =$
 $= 2^3 + 3 \cdot 2^2i + 3 \cdot 2i^2 + i^3 - 3(2^2 + 4i + i^2) + 8 + 4i - 8 =$
 $= 8 + 12i - 6 - i - 12 - 12i + 3 + 8 + 4i - 8 = -7 + 3i.$

Example 4 Express each of the following complex numbers in polar form.

Solution (a) $2 + 2\sqrt{3}i$ [See Fig.4]

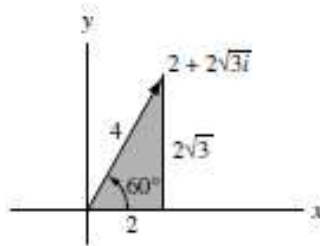

Fig. 4

Modulus or absolute value, $r = |2 + 2\sqrt{3}i| = \sqrt{4 + 12} = 4.$

Amplitude or argument, $\varphi = \arcsin \frac{\sqrt{3}}{2} = 60^\circ = \frac{\pi}{3}$ (radians).

Then

$$2 + 2\sqrt{3}i = r(\cos \varphi + i \sin \varphi) = 4(\cos 60^\circ + i \sin 60^\circ) = 4 \left(\cos \frac{\pi}{3} + i \sin \frac{\pi}{3} \right)$$

The result can also be written as, using Euler's formula, $4e^{\frac{\pi i}{3}}.$

(b) $-\sqrt{6} - \sqrt{2}i$ [See Fig.5]

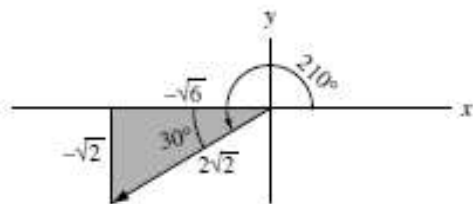

Fig.5

$$r = |-\sqrt{6} - \sqrt{2}i| = \sqrt{6+2} = 2\sqrt{2}$$

$$\varphi = 180^\circ + 30^\circ = 210^\circ = \frac{7\pi}{6}$$

Then

$$-\sqrt{6} - \sqrt{2}i = 2\sqrt{2} \left(\cos \frac{7\pi}{6} + i \sin \frac{7\pi}{6} \right) = 2\sqrt{2} e^{\frac{7\pi i}{6}}$$

(c) $-3i$ [See Fig.6]

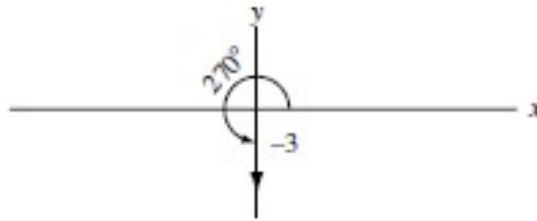

Fig.6

$$r = |-3i| = |0 - 3i| = \sqrt{0+9} = 3, \varphi = 270^\circ = \frac{3\pi}{2}$$

Then

$$-3i = 3 \left(\cos \frac{3\pi}{2} + i \sin \frac{3\pi}{2} \right) = 3e^{\frac{3\pi i}{2}}$$

Example 5 Find all values of z for which $z^5 = -32$, and (b) locate these values in the complex plane.

Solution

In polar form, $-32 = 32(\cos(\pi + 2\pi k) + i \sin(\pi + 2\pi k)), k = 0, \pm 1, \pm 2, \dots$

Let $z = r(\cos \varphi + i \sin \varphi)$. Then, by De Moivre's theorem,

$$z^5 = r^5(\cos 5\varphi + i \sin 5\varphi) = 32(\cos(\pi + 2\pi k) + i \sin(\pi + 2\pi k)).$$

and so $r^5 = 32, 5\varphi = \pi + 2\pi k$, from which $r = 2, \varphi = \frac{(\pi + 2\pi k)}{5}$. Hence

$$z = 2 \left(\cos \left(\frac{\pi + 2\pi k}{5} \right) + i \sin \left(\frac{\pi + 2\pi k}{5} \right) \right).$$

$$\text{If } k = 0, z = z_1 = 2 \left(\cos \frac{\pi}{5} + i \sin \frac{\pi}{5} \right).$$

$$\text{If } k = 1, z = z_2 = 2 \left(\cos \frac{3\pi}{5} + i \sin \frac{3\pi}{5} \right).$$

$$\text{If } k = 2, z = z_3 = 2 \left(\cos \frac{5\pi}{5} + i \sin \frac{5\pi}{5} \right) = -2.$$

$$\text{If } k = 3, z = z_4 = 2 \left(\cos \frac{7\pi}{5} + i \sin \frac{7\pi}{5} \right).$$

If $k = 4, z = z_5 = 2 \left(\cos \frac{9\pi}{5} + i \sin \frac{9\pi}{5} \right)$.

By considering $k = 5, 6, \dots$ as well as negative values, $-1, -2, \dots$, repetitions of the above five values of z are obtained. Hence, these are the only solutions or roots of the given equation.

These five roots are called the fifth roots of -32 and are collectively denoted by $(-32)^{\frac{1}{5}}$. In

general, $a^{\frac{1}{n}}$ represents the n -th roots of a and there are n such roots.

(b) The values of z are indicated in Fig.7. Note that they are equally spaced along the circumference of a circle with center at the origin and radius 2. Another way of saying this is that the roots are represented by the vertices of a regular polygon.

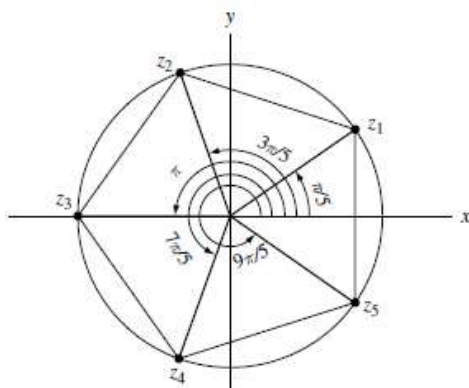

Fig.7

Example 6 Represent graphically the set of values of z for which (a) $\left| \frac{z-3}{z+3} \right| = 2$,

(b) $\left| \frac{z-3}{z+3} \right| < 2$.

Solution

The given equation is equivalent to $|z-3| = 2|z+3|$ or, if $z = x + iy$, $|x + iy - 3| = 2|x + iy + 3|$, i.e.,

$$\sqrt{(x-3)^2 + y^2} = 2\sqrt{(x+3)^2 + y^2}$$

Squaring and simplifying, this becomes

$$x^2 + y^2 + 10x + 9 = 0$$

or

$$(x+5)^2 + y^2 = 16$$

i.e., $|z+5| = 4$, a circle of radius 4 with center at $(-5, 0)$ as shown in Fig.8.

(b) The given inequality is equivalent to $|z-3| < 2|z+3|$ or $\sqrt{(x-3)^2 + y^2} < 2\sqrt{(x+3)^2 + y^2}$. Squaring and simplifying, this becomes $x^2 + y^2 + 10x + 9 > 0$ or $(x+5)^2 + y^2 > 16$, i.e., $|z+5| > 4$.

The required set thus consists of all points external to the circle of Fig.8.

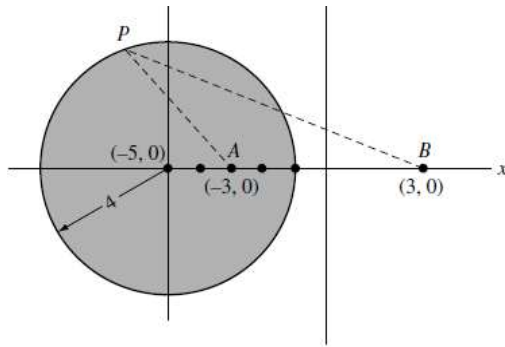

Fig.8

Exercise Set 1

In Exercises 1 to 9 perform each of the indicated operations:

1. $(2 - 3i) + (5 + 8i)$.
2. $(i - 2) \cdot ((4 - i) + 3(7 + 6i))$.
3. $(3 + i)(2 - i)(4 + 3i)$.
4. $\frac{3 - i}{5 + i}$.
5. $4i^5 - 3i^4 + 2i^3 + 7i - 1$.
6. $(2 - i)^2(3 + i)$.
7. $\frac{(4 - 6i)(i - 2)}{1 + i}$.
8. $(i^4 - 5i)(3i^3 + 2i + 1)$.
9. $\frac{i^4 + i^9 + i^{16}}{2 - i^5 + i^{10}}$.

In Exercises 10 to 12 suppose $z_1 = 2 + i$, $z_2 = 3 - 2i$. Evaluate each of the following:

10. $z_1^2 + 2z_1 - 3i + 5$.
11. $|2z_2 - 3z_1|^2$.
12. $|z_1\bar{z}_2 - 4\bar{z}_1z_2|$.

In Exercises 13 to 18 describe and graph the locus represented by each of the following

13. $|z - i| = 2$.
14. $|z + 2i| + |z - 2i| = 6$.
15. $|z - 3| - |z + 3| = 4$.
16. $z(\bar{z} + 2) = 3$.
17. $\text{Im}\{z^2\} = 4$.
18. $\text{Im}\{z\} \text{Re}\{z\} = 1$.

In Exercises 19 to 24 describe graphically the region represented by each of the following:

19. $1 < |z + i| \leq 2$.
20. $\text{Re}\{z^2\} > 1$.
21. $|z + 3i| > 4$.
22. $|z + 2| + |z - 2| < 10$.
23. $0 \leq \arg z < \frac{5\pi}{6}$.
24. $-\frac{\pi}{4} \leq \arg(z - i) < \frac{\pi}{2}$.

In Exercises 25 to 30 express each of the following complex numbers in polar form:

25. $2 - 2i$.
26. $-1 + \sqrt{3}i$.
27. $\sqrt{2}i$.
28. $-2\sqrt{3} - 2i$.
29. $\frac{\sqrt{3}}{2} - \frac{1}{2}i$.
30. -5 .

In Exercises 31 to 35 solve the following equations, obtaining all roots:

31. $z^2 + 4 = 0$.
32. $z^4 - 81 = 0$.
33. $z^3 - 27 = 0$.
34. $z^2 + 6z + 25 = 0$.
35. $z^4 + 5z^2 + 4 = 0$.
36. $z^2 - 2z + 5 = 0$.

2 Functions, Limits, and Continuity

2.1 Functions of Complex Variable

A symbol, such as z , which can stand for any one of a set of complex numbers is called a complex variable.

Suppose, to each value that a complex variable z can assume, there corresponds one or more values of a complex variable w . We then say that w is a function of z and write $w = f(z)$ or $w = G(z)$, etc. The variable z is sometimes called an independent variable, while w is called a dependent variable. The value of a function at $z = a$ is often written $f(a)$. Thus, if $f(z) = z^2$, then $f(2i) = (2i)^2 = -4$.

If only one value of w corresponds to each value of z , we say that w is a single-valued function of z or that $f(z)$ is single-valued. If more than one value of w corresponds to each value of z , we say that w is a multiple-valued or many-valued function of z .

A multiple-valued function can be considered as a collection of single-valued functions, each member of which is called a branch of the function. It is customary to consider one particular member as a principal branch of the multiple-valued function and the value of the function corresponding to this branch as the principal value.

Example 7

(a) If $w = z^2$, then to each value of z there is only one value of w . Hence, $w = f(z) = z^2$ is a single-valued function of z .

(b) If $w^2 = z$, then to each value of z there are two values of w . Hence, $w^2 = z$ defines a multiple-valued (in this case two-valued) function of z .

Whenever we speak of function, we shall, unless otherwise stated, assume a single-valued function. If $w = f(z)$, then we can also consider z as a function, possibly multiple-valued, of w , written $z = g(w) = f^{-1}(w)$. The function f^{-1} is often called the inverse function corresponding to f . Thus, $w = f(z)$ and $w = f^{-1}(z)$ are inverse functions of each other.

If $w = u + iv$ (where u and v are real) is a single-valued function of $z = x + iy$ (where x and y are real), we can write $u + iv = f(x + iy)$. By equating real and imaginary parts, this is seen to be equivalent to

$$u = u(x, y), \quad v = v(x, y) \quad (1)$$

Thus given a point (x, y) in the z plane, such as P in Fig.9, there corresponds a point (u, v) in the w plane, say P' in Fig.10. The set of equations (1) [or the equivalent, $w = f(z)$] is called a transformation. We say that point P is mapped or transformed into point P' by means of the transformation and call P' the image of P .

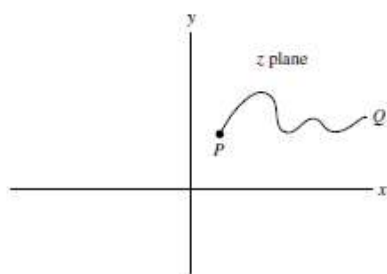

Fig.9

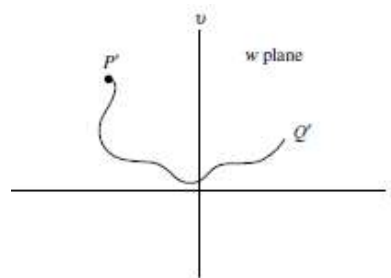

Fig.10

In general, under a transformation, a set of points such as those on curve PQ of Fig.9 is mapped into a corresponding set of points, called the image, such as those on curve $P'Q'$ in Fig.10. The particular characteristics of the image depend of course on the type of function $f(z)$, which is sometimes called a mapping function. If $f(z)$ is multiple-valued, a point (or curve) in the z plane is mapped in general into more than one point (or curve) in the w plane.

Example 8

If $w = z^2$, then $w = u + iv = (x + iy)^2 = x^2 - y^2 + 2xyi$ and the transformation is $u = x^2 - y^2, v = 2xy$. The image of a point (1,2) in the z plane is the point (-3,4) in the w plane.

2.2 The Elementary Functions

1. Polynomial Functions are defined by

$$w = a_0 z^n + a_1 z^{n-1} + \dots + a_n = P(z) \quad (1)$$

where $a_0 \neq 0, a_1, \dots, a_n$ are complex constants and n is a positive integer called the degree of the polynomial $P(z)$. The transformation $w = az + b$ is called a *linear transformation*.

2. Rational Algebraic Functions are defined by

$$w = \frac{P(z)}{Q(z)} \quad (2)$$

where $P(z)$ and $Q(z)$ are polynomials. We sometimes call (2) a rational transformation. The special case $w = \frac{az + b}{cz + d}$ where $ad - bc \neq 0$ is often called a bilinear or fractional linear transformation.

3. Exponential Functions are defined by

$$w = e^z = e^{x+iy} = e^x (\cos y + i \sin y) \quad (3)$$

where e is the natural base of logarithms. If a is real and positive, we define

$$a^z = e^{z \ln a} \quad (4)$$

where $\ln a$ is the natural logarithm of a . This reduces to (3) if $a = e$.

Complex exponential functions have properties similar to those of real exponential functions. For example, $e^{z_1} \cdot e^{z_2} = e^{z_1+z_2}$.

4. Trigonometric Functions. We define the trigonometric or circular functions $\sin z, \cos z$, etc., in terms of exponential functions as follows:

$$\sin z = \frac{e^{iz} - e^{-iz}}{2i}, \quad \cos z = \frac{e^{iz} + e^{-iz}}{2}, \quad \operatorname{tg} z = \frac{\sin z}{\cos z}, \quad \operatorname{ctg} z = \frac{\cos z}{\sin z} \quad (5)$$

Many of the properties familiar in the case of real trigonometric functions also hold for the complex trigonometric functions. For example, we have:

$$\sin^2 z + \cos^2 z = 1; 1 + \operatorname{tg}^2 z = \frac{1}{\cos^2 z}; \sin(-z) = -\sin z; \cos(-z) = \cos z.$$

5. Hyperbolic Functions are defined as follows:

$$\operatorname{sh} z = \frac{e^z - e^{-z}}{2}, \quad \operatorname{ch} z = \frac{e^z + e^{-z}}{2}, \quad \operatorname{th} z = \frac{e^z - e^{-z}}{e^z + e^{-z}}, \quad \operatorname{cth} z = \frac{e^z + e^{-z}}{e^z - e^{-z}} \quad (6)$$

The following relations exist between the trigonometric or circular functions and the hyperbolic functions:

$$\begin{aligned} \operatorname{sh} z &= -i \sin(iz), & \operatorname{ch} z &= \cos(iz), \\ \sin z &= \sin x \cdot \operatorname{ch} y + i \cos x \cdot \operatorname{sh} y, \\ \cos z &= \cos x \cdot \operatorname{ch} y - i \sin x \cdot \operatorname{sh} y. \end{aligned}$$

6. Logarithmic Functions. If $z = e^w$, then we write $w = \ln z$, called the natural logarithm of z . Thus the natural logarithmic function is the inverse of the exponential function and can be defined by

$$w = \operatorname{Ln} z = \ln|z| + i \arg z + i2k\pi, \quad k \in Z \quad (7)$$

where $z = r e^{i\varphi} = r e^{i(\varphi + 2k\pi)}$. Note that $\ln z$ is a multiple-valued (in this case, infinitely many-valued) function. The principal-value or principal branch of $\ln z$ is sometimes defined as $\ln r + i\varphi$, where $0 \leq \varphi < 2\pi$. However, any other interval of length 2π can be used, e.g., $-\pi < \varphi \leq \pi$, etc.

The logarithmic function can be defined for real bases other than e . Thus, if $z = a^w$, then $w = \log_a z$, where $a > 0$ and $a \neq 0, 1$. In this case, $z = e^{w \ln a}$ and so, $w = \frac{\ln z}{\ln a}$.

7. Inverse Trigonometric Functions. If $z = \sin w$, then $w = \sin^{-1} z$ is called the inverse sine of z or arcsin of z . Similarly, we define other inverse trigonometric or circular functions $\cos^{-1} z$, $\operatorname{tg}^{-1} z$, etc. These functions, which are multiple-valued, can be expressed in terms of natural logarithms as follows. In all cases, we omit an additive constant $2k\pi i$, $k \in Z$ in the logarithm:

$$\begin{aligned} w = \operatorname{Arcsin} z &= -i \operatorname{Ln} \left(iz + \sqrt{1 - z^2} \right), & w = \operatorname{Arccos} z &= -i \operatorname{Ln} \left(z + \sqrt{z^2 - 1} \right), \\ w = \operatorname{Arctg} z &= \frac{1}{2i} \operatorname{Ln} \frac{1 + iz}{1 - iz}, & w = \operatorname{Arcctg} z &= -\frac{1}{2i} \operatorname{Ln} \frac{1 + iz}{iz - 1} \end{aligned} \quad (8)$$

8. The Function z^α , where α may be complex, is defined as $e^{\alpha \ln z}$. Similarly, if $f(z)$ and $g(z)$ are two given functions of z , we can define $f^{g(z)}(z) = e^{g(z) \ln f(z)}$. In general, such functions are multiple-valued.

9. Algebraic and Transcendental Functions. If w is a solution of the polynomial equation

$$P_0(z)w^n + P_1(z)w^{n-1} + \dots + P_{n-1}(z)w + P_n(z) = 0 \quad (9)$$

where $P_0 \neq 0, P_1(z), \dots, P_n(z)$ are polynomials in z and n is a positive integer, then $w = f(z)$ is called an algebraic function of z .

Any function that cannot be expressed as a solution of (9) is called a transcendental function. The logarithmic, trigonometric, and hyperbolic functions and their corresponding inverses are examples of transcendental functions.

The functions considered in 1–8 above, together with functions derived from them by a finite number of operations involving addition, subtraction, multiplication, division and roots are called elementary functions.

Example 9 Determine the values of (a) i^{1+i} , (b) $\text{Arcsin } 3$, (c) $\text{Ln}(12 + 5i)$.

Solution

$$\begin{aligned} \text{(a) } i^{1+i} &= e^{(1+i)\text{Ln}i} = e^{(1+i)(\ln|i| + i\arg i + 2k\pi i)} = e^{(1+i)\left(\frac{i\pi}{2} + 2k\pi i\right)} = e^{(i-1)\left(\frac{\pi}{2} + 2k\pi\right)} = \\ &= e^{-\left(\frac{\pi}{2} + 2k\pi\right)} \cdot e^{i\left(\frac{\pi}{2} + 2k\pi\right)} = e^{-\left(\frac{\pi}{2} + 2k\pi\right)} \left(\cos\left(\frac{\pi}{2} + 2k\pi\right) + i \sin\left(\frac{\pi}{2} + 2k\pi\right) \right) = \\ &= i e^{-\left(\frac{\pi}{2} + 2k\pi\right)}, k \in \mathbb{Z}. \end{aligned}$$

$$\begin{aligned} \text{(b) } \text{Arcsin } 3 &= -i \text{Ln}(3i \pm i\sqrt{8}) = -i \text{Ln}\left(\left(3 \pm 2\sqrt{2}\right)i\right) = \\ &= -i \left(\ln\left(3 \pm 2\sqrt{2}\right) + i\frac{\pi}{2} + 2k\pi i \right) = \frac{\pi}{2} + 2k\pi - i \ln\left(3 \pm 2\sqrt{2}\right), k \in \mathbb{Z}. \end{aligned}$$

$$\begin{aligned} \text{(c) } \text{Ln}(12 + 5i) &= \ln|12 + 5i| + i \arg(12 + 5i) + i2k\pi = \\ &= \left| \begin{array}{l} |12 + 5i| = \sqrt{144 + 25} = 13, \\ 12 > 0, 5 > 0, \arg(12 + 5i) = \text{arctg} \frac{5}{12} \end{array} \right| = \ln 13 + i \left(\text{arctg} \frac{5}{12} + 2k\pi \right), k \in \mathbb{Z}. \end{aligned}$$

Example 10 Show that the line joining the points $P(-2,1)$ and $Q(1,-3)$ in the z plane is mapped by $w = z^2$ into curve joining points $P'Q'$ [Fig.11] and determine the equation of this curve.

Solution

Points P and Q have coordinates $(-2,1)$ and $(1,-3)$. Then, the parametric equations of the line joining these points are given by

$$\frac{x - (-2)}{1 - (-2)} = \frac{y - 1}{-3 - 1} = t \quad \text{or} \quad \begin{cases} x = 3t - 2, \\ y = 1 - 4t. \end{cases}$$

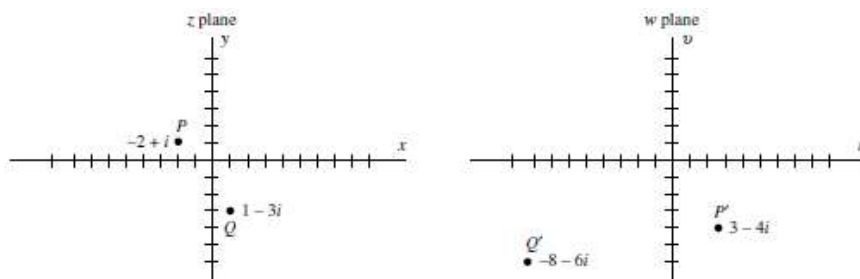

Fig.11

The equation of the line PQ can be represented by $z = 3t - 2 + i(1 - 4t)$. The curve in the w plane into which this line is mapped has the equation

$$\begin{aligned} w = z^2 &= (3t - 2 + i(1 - 4t))^2 = (3t - 2)^2 - (1 - 4t)^2 + 2(3t - 2)(1 - 4t)i = \\ &= 3 - 4t - 7t^2 + (-4 + 22t - 24t^2)i. \end{aligned}$$

Then, since $w = u + iv$, the parametric equations of the image curve are given by

$$u = 3 - 4t - 7t^2 \text{ and } v = -4 + 22t - 24t^2.$$

By assigning various values to the parameter t , this curve may be graphed.

2.3 Limits. Continuity

Let $f(z)$ be defined and single-valued in a neighborhood of $z = z_0$ with the possible exception of $z = z_0$ itself (i.e., in a deleted δ neighborhood of z_0). We say that the number L is the limit of $f(z)$ as z approaches z_0 and write $\lim_{z \rightarrow z_0} f(z) = L$ if for any positive number ε (however small), we can find some positive number δ (usually depending on ε) such that $|f(z) - L| < \varepsilon$ whenever $0 < |z - z_0| < \delta$.

In such a case, we also say that $f(z)$ approaches L as z approaches z_0 and write $f(z) \rightarrow L$ as $z \rightarrow z_0$. The limit must be independent of the manner in which z approaches z_0 .

Geometrically, if z_0 is a point in the complex plane, then $\lim_{z \rightarrow z_0} f(z) = L$ if the difference in absolute value between $f(z)$ and L can be made as small as we wish by choosing points z sufficiently close to z_0 (excluding $z = z_0$ itself).

By means of the transformation $w = \frac{1}{z}$, the point $z = 0$ (i.e., the origin) is mapped into $w = \infty$, called the point at infinity in the w plane. Similarly, we denote by $z = \infty$, the point at infinity in the z plane. To consider the behavior of $f(z)$ at $z = \infty$, it suffices to let $z = \frac{1}{w}$ and

examine the behavior of $f\left(\frac{1}{w}\right)$ at $w = 0$.

We say that $\lim_{z \rightarrow z_0} f(z) = L$ or $f(z)$ approaches L as z approaches infinity, if for any $\varepsilon > 0$, we can find $M > 0$ such that $|f(z) - L| < \varepsilon$ whenever $|z| > M$.

We say that $\lim_{z \rightarrow z_0} f(z) = \infty$ or $f(z)$ approaches infinity as z approaches z_0 , if for any $N > 0$, we can find $\delta > 0$ such that $|f(z)| > N$ whenever $0 < |z - z_0| < \delta$.

Let $f(z)$ be defined and single-valued in a neighborhood of $z = z_0$ as well as at $z = z_0$ (i.e., in a δ neighborhood of z_0). The function $f(z)$ is said to be continuous at $z = z_0$ if $\lim_{z \rightarrow z_0} f(z) = f(z_0)$. Note that this implies three conditions that must be met in order that $f(z)$

be continuous at $z = z_0$:

1. $\lim_{z \rightarrow z_0} f(z) = L$ must exist;
2. $f(z_0)$ must exist, i.e., $f(z)$ is defined at z_0 ;
3. $L = f(z_0)$.

Equivalently, if $f(z)$ is continuous at z_0 , we can write this in the suggestive form

$$\lim_{z \rightarrow z_0} f(z) = f\left(\lim_{z \rightarrow z_0} z\right).$$

Points in the z plane where $f(z)$ fails to be continuous are called discontinuities of $f(z)$, and $f(z)$ is said to be discontinuous at these points. If $\lim_{z \rightarrow z_0} f(z)$ exists but is not equal to $f(z_0)$, we call z_0 a removable discontinuity since by redefining $f(z_0)$ to be the same as $\lim_{z \rightarrow z_0} f(z)$, the function becomes continuous.

Alternative to the above definition of continuity, we can define $f(z)$ as continuous at $z = z_0$ if for any $\varepsilon > 0$, we can find $\delta > 0$ such that $|f(z) - f(z_0)| < \varepsilon$ whenever $|z - z_0| < \delta$. Note that this is simply the definition of limit with $L = f(z_0)$ and removal of the restriction that $z \neq z_0$.

To examine the continuity of $f(z)$ at $z = \infty$, we let $z = \frac{1}{w}$ and examine the continuity of $f\left(\frac{1}{w}\right)$ at $w = 0$.

A function $f(z)$ is said to be continuous in a region if it is continuous at all points of the region.

Exercise Set 2

1. Let $w = f(z) = z(2 - z)$. Find the values of w corresponding to (a) $z = 1 + i$, (b) $z = 2 - 2i$ and graph corresponding values in the w and z planes.

2. Let $w = f(z) = \frac{1+z}{1-z}$. Find: (a) $f(i)$, (b) $f(1-i)$ and represent graphically.

In Exercises 3 to 8 separate each of the following into real and imaginary parts, i.e., find $u(x, y)$ and $v(x, y)$ such that $f(z) = u + iv$:

3. $w = (2 - 3i)z^2 - iz - i$. 4. $w = |z| \cdot \operatorname{Re} z$. 5. $w = \frac{z-i}{z+i}$.

6. $w = 5iz - iz^2 - 1$. 7. $w = \bar{z} \cdot \operatorname{Im} z$. 8. $w = 3z^2 - 2iz + 8$.

9. Find all values of z for which (a) $e^{3z} = 1$, (b) $e^{4z} = i$.

In Exercises 9 to 21 find the value of

10. $\operatorname{Ln}(\sqrt{3} - i)$. 11. $\operatorname{Ln}(1 + \sqrt{3}i)$. 12. $\operatorname{Ln}(-1 - i)$.

13. $\sin\left(\frac{3\pi}{4} + i\right)$. 14. $\cos\left(\frac{\pi}{6} - i\right)$. 15. $\operatorname{tg}\frac{\pi}{2}i$.

16. $\operatorname{sh}\left(1 - \frac{\pi}{2}i\right)$. 17. $\operatorname{ch}\left(2 + \frac{\pi}{4}i\right)$. 18. $(\sqrt{3} + i)^{6i}$.

$$19. \operatorname{Arcsin}(-2 + \sqrt{2}i). \quad 20. \operatorname{Arcos}(2 - \sqrt{3}i). \quad 21. \operatorname{Arctg} \frac{12 - 5i}{13}.$$

In Exercises 22 to 28 determine the types of the curves given by the equation

$$22. |z - 3e^{it}| = \left| \frac{1}{2} \frac{z + 2\bar{z}}{e^{it}} \right|. \quad 23. \operatorname{Im}(z^2 + 4t) = 20 - \operatorname{Im}(z^2 + 4t + 4).$$

$$26. z = \frac{2+t}{2-t} + i \frac{1+t}{1-t}. \quad 27. z = \frac{1+t}{1-t} + i \frac{2+t}{2-t}.$$

3 Complex Differentiation and the Cauchy–Riemann Equations

3.1 Derivatives. Analytic Functions. Cauchy–Riemann Equations. Geometric Interpretation of the Derivative

If $f(z)$ is single-valued in some region \mathbb{R} of the z plane, the derivative of $f(z)$ is defined as

$$f'(z) = \lim_{\Delta z \rightarrow 0} \frac{f(z + \Delta z) - f(z)}{\Delta z} \quad (1)$$

provided that the limit exists independent of the manner in which $\Delta z \rightarrow 0$. In such a case, we say that $f(z)$ is differentiable at z . In the definition (1), we sometimes use h instead of Δz . Although differentiability implies continuity, the reverse is not true.

If the derivative $f'(z)$ exists at all points z of a region \mathbb{R} , then $f(z)$ is said to be analytic in \mathbb{R} and is referred to as an analytic function in \mathbb{R} or a function analytic in \mathbb{R} . The terms regular and holomorphic are sometimes used as synonyms for analytic.

A function $f(z)$ is said to be analytic at a point z_0 if there exists a neighborhood $|z - z_0| < \delta$ at all points of which $f'(z)$ exists.

A necessary condition that $w = f(z) = u(x, y) + iv(x, y)$ be analytic in a region \mathbb{R} is that, in \mathbb{R} , $u(x, y)$ and $v(x, y)$ satisfy the Cauchy–Riemann equations

$$\frac{\partial u}{\partial x} = \frac{\partial v}{\partial y}, \quad \frac{\partial u}{\partial y} = -\frac{\partial v}{\partial x} \quad (2)$$

If the partial derivatives in (2) are continuous in \mathbb{R} , then the Cauchy–Riemann equations are sufficient conditions that $f(z)$ be analytic in \mathbb{R} .

The functions $u(x, y)$ and $v(x, y)$ are sometimes called conjugate functions. Given $u(x, y)$ having continuous first partials on a simply connected region \mathbb{R} , we can find $v(x, y)$ (within an arbitrary additive constant) so that $u + iv = w = f(z)$ is analytic.

If the second partial derivatives of $u(x, y)$ and $v(x, y)$ with respect to x and y exist and are continuous in a region \mathbb{R} , then we find from (2) that

$$\frac{\partial^2 u}{\partial x^2} + \frac{\partial^2 u}{\partial y^2} = 0, \quad \frac{\partial^2 v}{\partial x^2} + \frac{\partial^2 v}{\partial y^2} = 0 \quad (3)$$

Functions such as $u(x, y)$ and $v(x, y)$ which satisfy Laplace's equation in a region \mathbb{R} are

called harmonic functions and are said to be harmonic in \mathbb{R} .

Let z_0 [Fig.12] be a point P in the z plane and let w_0 [Fig.13] be its image P' in the w plane under the transformation $w = f(z)$. Since we suppose that $f(z)$ is single-valued, the point z_0 maps into only one point w_0 .

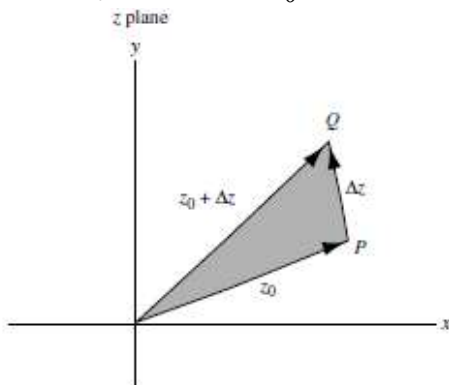

Fig.12

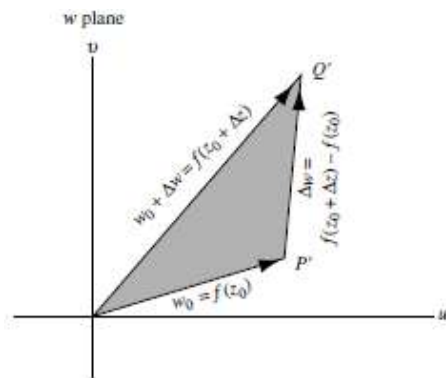

Fig.13

If we give z_0 an increment Δz , we obtain the point Q of Fig.12. This point has image Q' in the w plane.

Thus, from Fig.13, we see that $P'Q'$ represents the complex number $\Delta w = f(z_0 + \Delta z) - f(z_0)$. It follows that the derivative at z_0 (if it exists) is given by

$$\lim_{\Delta z \rightarrow 0} \frac{f(z_0 + \Delta z) - f(z_0)}{\Delta z} = \lim_{Q \rightarrow P} \frac{P'Q'}{PQ} \quad (4)$$

that is, the limit of the ratio $P'Q'$ to PQ as point Q approaches point P . The above interpretation clearly holds when z_0 is replaced by any point z .

Example 11 Find out which of the following functions are analytic at least at one point

- (a) $w = (2 + 5i)z - iz^2 + 3i$; (b) $w = z^2 \cdot \bar{z}$.

Solution

(a) If $z = x + iy$, then

$$w = (2 + 5i)z - iz^2 + 3i = (2 + 5i)(x + iy) - i(x + iy)^2 + 3i = 2x - 5y + i(5x + 2y) + 2xy - i(x^2 - y^2) - 3i = (x - 5y + 2xy) + i(-x^2 + y^2 + 5x + 2y - 3)$$

$$u = x - 5y + 2xy, \quad v = y^2 - x^2 + 5x + 2y - 3$$

$$u'_x = (x - 5y + 2xy)'_x = 1 + 2y, \quad u'_y = (x - 5y + 2xy)'_y = -5 + 2x.$$

$$v'_x = (y^2 - x^2 + 5x + 2y - 3)'_x = -2x + 5, \quad v'_y = (y^2 - x^2 + 5x + 2y - 3)'_y = 2y + 2.$$

From the Cauchy–Riemann equations

$$\begin{cases} u'_x = v'_y \\ u'_y = -v'_x \end{cases}, \quad \begin{cases} 1 + 2y = 2y + 2 \\ -5 + 2x = 2x - 5 \end{cases}, \quad \begin{cases} 1 = 2 \\ 0 = 0 \end{cases}$$

The system has no solution, then the function is not analytic at any points of the complex plane.

(b) If $z = x + iy$, then

$$w = z^2 \cdot \bar{z} = (x + iy)^2(x - iy) = (x^2 - y^2 + 2xyi)(x - iy) = (x^3 + xy^2) + i(x^2y + y^3).$$

$$\begin{aligned}
 u &= x^3 + xy^2, & v &= x^2y + y^3. \\
 u'_x &= (x^3 + xy^2)'_x = 3x^2 + y^2, & u'_y &= (x^3 + xy^2)'_y = 2xy, \\
 v'_x &= (x^2y + y^3)'_x = 2xy, & v'_y &= (x^2y + y^3)'_y = x^2 + 3y^2.
 \end{aligned}$$

From the Cauchy–Riemann equations

$$\begin{cases} u'_x = v'_y \\ u'_y = -v'_x \end{cases}, \quad \begin{cases} 3x^2 + y^2 = x^2 + 3y^2 \\ 2xy = -2xy \end{cases}, \quad \begin{cases} x^2 = y^2 \\ 4xy = 0 \end{cases}, \quad \begin{cases} x = 0 \\ y = 0 \end{cases}.$$

Given function is analytic at origin.

Example 12

- (a) Prove that $v = x^2 - y^2 + 2x + 1$ is harmonic;
 (b) Find $u(x, y)$ such that $f(z) = u + iv$ is analytic.

Solution

(a) $v'_x = 2x + 2, \quad v'_y = -2y.$

$$v''_{xx} = 2, \quad v''_{yy} = -2.$$

Adding v''_{xx} and v''_{yy} yields $\frac{\partial^2 v}{\partial x^2} + \frac{\partial^2 v}{\partial y^2} = 0$ and v is harmonic.

(b) From the Cauchy–Riemann equations

$$\begin{cases} u'_x = v'_y = -2y, \\ u'_y = -v'_x = -2x - 2. \end{cases}$$

Integrate u'_y with respect to y , keeping x constant. Then

$$u = \int (-2x - 2)dy = -2xy - 2y + F(x),$$

where $F(x)$ is an arbitrary real function of x .

Substitute $-2xy - 2y + F(x)$ into $u'_x = -2y$ and obtain $-2y + F'(x) = -2y$ or $F'(x) = 0$ and $F(x) = c$, a constant. Then, $u(x, y) = -2xy - 2y + c$.

Example 13 Find a coefficient of expansion and the rotation angle at this point when mapping $w = u(x, y) + iv(x, y)$:

$$u(x, y) = 3x^2y - y^3, \quad v(x, y) = 3xy^2 - x^3, \quad z_0 = 1 - i.$$

Solution

From the Cauchy–Riemann equations

$$\begin{cases} u'_x = v'_y = 6xy, \\ u'_y = -v'_x = 3x^2 - 3y^2, \end{cases}$$

for all points of the complex plane. Then

$$f'(z) = u'_x + iv'_x = v'_y(x, y) - iu'_y(x, y),$$

$$f'(z) = u'_x + iv'_x = 6xy + i(3y^2 - 3x^2)$$

and find the value of the set point $z_0 = 1 - i$

$$f'(1-i) = \left(6xy + i(3y^2 - 3x^2)\right) \Big|_{\substack{x=1 \\ y=-1}} = -6.$$

A coefficient of expansion equals modulus of a complex number $f'(1-i) = -6 + 0i$,

$$|-6 + 0i| = \sqrt{36 + 0} = 6.$$

The rotation angle equals the argument of $f'(1-i) = -6 + 0i$

$$\arg z = \varphi = \operatorname{arctg} \frac{0}{-6} = \pi.$$

Exercise Set 3

In Exercises 1 to 6 find out which of the following functions are analytic at least at one point

1. $w = i \cos z$.
2. $w = |z| \cdot \operatorname{Re} z$.
3. $w = \bar{z} \cdot \operatorname{Im} z$.
4. $w = \frac{z-i}{z+i}$.
5. $w = (2+5i)z - iz^2 + 3i$.
6. $w = (3+4i)z^2 + 7iz + 6$.

In Exercises 7 to 12 prove that given function is harmonic. Find $u(x, y)$ or $v(x, y)$ such that $f(z) = u + iv$ is analytic.

7. $u = \frac{x}{x^2 + y^2} + x$, $f(1) = 2$.
8. $u = 1 - e^x \sin y$, $f(0) = 1 + i$.
10. $v = 3x^2y - y^3$, $f(0) = 1$.
9. $u = e^{-y} \cos x + x$, $f(0) = 1$.
11. $u = 3x^2y - y^3$, $f(1-i) = 0$.
12. $v = -e^{1+y} \sin x$, $f\left(\frac{\pi}{4} + i\right) = 0$.

In Exercises 13 to 16 find a coefficient of expansion and the rotation angle at this point when mapping

13. $u(x, y) = x^2 + 2x - y^2$, $v(x, y) = 2xy + 2y$, $z_0 = i$.
14. $u(x, y) = x^3 - 3xy^2 + x^2 - y^2$, $v(x, y) = 3x^2y - y^3 + 2xy$, $z_0 = \frac{2i}{3}$.
15. $u(x, y) = x^3 - 3xy^2 + 3x$, $v(x, y) = 3x^2y - y^3 + 3y - 1$, $z_0 = -1 + i$.
16. $u(x, y) = e^{1+y} \cos x$, $v(x, y) = -e^{1+y} \sin x$, $z_0 = \frac{\pi}{4} + i$.

3.2 Differentials. Rules for Differentiation. Derivatives of Elementary Functions

Let $\Delta z = dz$ be an increment given to z . Then

$$\Delta w = f(z + \Delta z) - f(z) \quad (1)$$

is called the increment in $w = f(z)$. If $f(z)$ is continuous and has a continuous first derivative in a region, then

$$\Delta w = f'(z)\Delta z + \varepsilon\Delta z \quad (2)$$

where $\varepsilon \rightarrow 0$ as $\Delta z \rightarrow 0$. The expression

$$dw = f'(z)dz \quad (3)$$

is called the differential of w or $f(z)$, or the principal part of Δw . Note that $\Delta w \neq dw$ in general. We call dz the differential of z .

Suppose $f(z)$, $g(z)$ are analytic functions of z . Then the following differentiation rules (identical with those of elementary calculus) are valid.

$$1. (f \pm g)' = f' \pm g'.$$

$$2. (cf)' = cf' \text{ where } c \text{ is any constant.}$$

$$3. (fg)' = f'g + g'f.$$

$$4. \left(\frac{f}{g}\right)' = \frac{f'g - g'f}{g^2} \text{ if } g(z) \neq 0.$$

$$5. (f(g(z)))' = f'_g \cdot g'_z.$$

$$6. \text{If } z = f(t) \text{ and } w = g(t) \text{ where } t \text{ is parameter, then } w'_z = \frac{g'(t)}{f'(t)}.$$

In the following, we assume that the functions are defined as in Chapter 2.2.2. In the cases where functions have branches, i.e., are multi-valued, the branch of the function on the right is chosen so as to correspond to the branch of the function on the left. Note that the results are identical with those of elementary calculus.

1. $(c)' = 0.$	2. $(z^n)' = nz^{n-1}.$
3. $(e^z)' = e^z.$	4. $(a^z)' = a^z \ln a.$
5. $(\ln z)' = \frac{1}{z}.$	6. $(\log_a z)' = \frac{1}{z \ln a}.$
7. $(\sin z)' = \cos z.$	8. $(\cos z)' = -\sin z.$
9. $(\operatorname{tg} z)' = \frac{1}{\cos^2 z}.$	10. $(\operatorname{ctg} z)' = -\frac{1}{\sin^2 z}.$
11. $(\arcsin z)' = \frac{1}{\sqrt{1-z^2}}.$	12. $(\arccos z)' = -\frac{1}{\sqrt{1-z^2}}.$
13. $(\operatorname{arctg} z)' = \frac{1}{1+z^2}.$	14. $(\operatorname{arcctg} z)' = -\frac{1}{1+z^2}.$
15. $(\operatorname{sh} z)' = \operatorname{ch} z.$	16. $(\operatorname{ch} z)' = \operatorname{sh} z.$
17. $(\operatorname{th} z)' = \frac{1}{\operatorname{ch}^2 z}.$	18. $(\operatorname{cth} z)' = -\frac{1}{\operatorname{sh}^2 z}.$

3.3 Higher Order Derivatives. L'Hospital's Rule. Singular Points

If $w = f(z)$ is analytic in a region, its derivative is given by $f'(z)$, w' or $\frac{dw}{dz}$. If $f'(z)$ is also analytic in the region, its derivative is denoted by $f''(z)$, w'' , or $\frac{d^2w}{dz^2}$. Similarly, the

n - th derivative of $f(z)$, if it exists, is denoted by $f^{(n)}(z)$, $w^{(n)}$, or $\frac{d^n w}{dz^n}$ where n is called the order of the derivative. Thus derivatives of first, second, third, ... orders are given by $f'(z)$, $f''(z)$, Computations of these higher order derivatives follow repeated application of the above differentiation rules.

One of the most remarkable theorems valid for functions of a complex variable and not necessarily valid for functions of a real variable is the following:

THEOREM 1 Suppose $f(z)$ is analytic in a region \mathbb{R} . Then so also are $f'(z)$, $f''(z)$, ... analytic in \mathbb{R} , i.e., all higher derivatives exist in \mathbb{R} .

Let $f(z)$ and $g(z)$ be analytic in a region containing the point z_0 and suppose that $f(z_0) = g(z_0) = 0$ but $g'(z_0) \neq 0$. Then, L'Hospital's rule states that

$$\lim_{z \rightarrow z_0} \frac{f(z)}{g(z)} = \frac{f'(z_0)}{g'(z_0)} \quad (1)$$

In the case of $f'(z_0) = g'(z_0) = 0$, the rule may be extended.

We sometimes say that the left side of (1) has the "indeterminate form" $\left(\frac{0}{0}\right)$, although such terminology is somewhat misleading since there is usually nothing indeterminate involved. Limits represented by so-called indeterminate forms $\left(\frac{\infty}{\infty}\right)$, $(0 \cdot \infty)$, $(\infty - \infty)$ and (1^∞) can often be evaluated by appropriate modifications of L'Hospital's rule.

A point at which $f(z)$ fails to be analytic is called a singular point or singularity of $f(z)$. Various types of singularities exist.

1. Isolated Singularities. The point $z = z_0$ is called an isolated singularity or isolated singular point of $f(z)$ if we can find $\delta > 0$ such that the circle $|z - z_0| = \delta$ encloses no singular point other than z_0 (i.e., there exists a deleted δ neighborhood of z_0 containing no singularity). If no such δ can be found, we call z_0 a non-isolated singularity.

If z_0 is not a singular point and we can find $\delta > 0$ such that $|z - z_0| = \delta$ encloses no singular point, then we call z_0 an ordinary point of $f(z)$.

2. Poles. If z_0 is an isolated singularity and we can find a positive integer n such that $\lim_{z \rightarrow z_0} (z - z_0)^n f(z) = A \neq 0$, then $z = z_0$ is called a pole of order n . If $n = 1$, z_0 is called a *simple pole*.

3. Branch Points of multiple-valued functions, already considered in Chapter 2.2.2, are non-isolated singular points since a multiple-valued function is not continuous and, therefore, not analytic in a deleted neighborhood of a branch point.

4. Removable Singularities. An isolated singular point z_0 is called a removable singularity of $f(z)$ if $\lim_{z \rightarrow z_0} f(z)$ exists. By defining $f(z_0) = \lim_{z \rightarrow z_0} f(z)$, it can then be shown that $f(z)$ is not only continuous at z_0 but is also analytic at z_0 .

5. Essential Singularities. An isolated singularity that is not a pole or removable singularity is called an *essential singularity*. If a function has an isolated singularity, then the singularity is either removable, a pole, or an essential singularity. For this reason, a pole is sometimes called a *non-essential singularity*. Equivalently, $z = z_0$ is an essential singularity if we cannot find any positive integer n such that $\lim_{z \rightarrow z_0} (z - z_0)^n f(z) = A \neq 0$.

6. Singularities at Infinity. The type of singularity of $f(z)$ at $z = \infty$ [the point at infinity] is the same as that of $f\left(\frac{1}{w}\right)$ at $w = 0$.

For methods of classifying singularities using infinite series, see next chapter.

Example 14 Using rules of differentiation, find the derivatives of each of the following:

(a) $\cos^2(2z + 3i)$, (b) $z \operatorname{tg}(\ln z)$, (c) $(z - 3i)^{4z+2}$

Solution Using the chain rule, we have

(a) $\left(\cos^2(2z + 3i)\right)' = -2 \cos(2z + 3i) \sin(2z + 3i) 2 = -4 \sin(4z + 6i)$.

(b) $(z \cdot \operatorname{tg}(\ln z))' = \operatorname{tg}(\ln z) + (\operatorname{tg}(\ln z))' \cdot z = \operatorname{tg}(\ln z) + \frac{z}{\cos^2 \ln z} \cdot \frac{1}{z}$.

(c) $\left((z - 3i)^{4z+2}\right)' = \left(e^{(4z+2)\ln(z-3i)}\right)' = e^{(4z+2)\ln(z-3i)} \cdot \left(4 \ln(z - 3i) + \frac{4z + 2}{z - 3i}\right)$.

Example 15 Suppose $w^3 - 3z^2w + 4 \ln z = 0$. Find $\frac{dw}{dz}$

Solution

Differentiating with respect to z , considering w as an implicit function of z , we have

$$3w^2w' - 3z^2w' - 6zw + \frac{4}{z} = 0.$$

Then, solving for $\frac{dw}{dz}$, we obtain $\frac{dw}{dz} = \frac{4zw - \frac{4}{z}}{3w^2 - 3z^2}$.

Example 16 Evaluate

(a) $\lim_{z \rightarrow i} \frac{z^{10} + 1}{z^6 + 1}$, (b) $\lim_{z \rightarrow 0} \frac{1 - \cos z}{z^2}$.

Solution

(a) Let $f(z) = z^{10} + 1$ and $g(z) = z^6 + 1$. Then $f(i) = g(i) = 0$. Also, $f(z), g(z)$ are analytic at $z = i$.

Hence, by L'Hospital's rule

$$\lim_{z \rightarrow i} \frac{z^{10} + 1}{z^6 + 1} = \left(\frac{0}{0}\right) = \lim_{z \rightarrow i} \frac{10z^9}{6z^5} = \lim_{z \rightarrow i} \frac{5}{3} z^4 = \frac{5}{3}.$$

(b) Let $f(z) = 1 - \cos z$ and $g(z) = z^2$. Then $f(0) = g(0) = 0$. Also, $f(z), g(z)$ are analytic at $z = 0$.

Hence, by L'Hospital's rule

$$\lim_{z \rightarrow 0} \frac{1 - \cos z}{z^2} = \left(\frac{0}{0} \right) = \lim_{z \rightarrow 0} \frac{\sin z}{2z} = \frac{1}{2} \lim_{z \rightarrow 0} \frac{\sin z}{z} = \frac{1}{2}.$$

Example 17 (a) $f(z) = \frac{1}{(z-3)^4}$ has a pole of order 4 at $z = 3$.

(b) $f(z) = \frac{3z-2}{(z-1)^2(z+1)(z-4)}$ has a pole of order 2 at $z = 1$, and simple poles at $z = -1$ and $z = 4$.

(c) $f(z) = (z-3)^{\frac{1}{2}}$ has a branch point at $z = 3$.

(d) $f(z) = \ln(z^2 + z - 2)$ has branch points where $z^2 + z - 2 = 0$, i.e., at $z = 1$ and $z = -2$.

(e) The singular point $z = 0$ is a removable singularity of $f(z) = \frac{\sin z}{z}$ since $\lim_{z \rightarrow 0} \frac{\sin z}{z} = 1$.

(f) $f(z) = e^{\frac{1}{z-2}}$ has an essential singularity at $z = 2$.

(g) The function $f(z) = z^3$ has a pole of order 3 at $z = \infty$, since $f\left(\frac{1}{w}\right) = \frac{1}{w^3}$ has a pole of order 3 at $w = 0$.

Exercise Set 4

In Exercises 1 to 9 using rules of differentiation, find the derivatives of each of the following:

1. $\sin^3(5z + 7i)$.
2. $\ln(\operatorname{tg} 5z)$.
3. ze^{z-i} .
4. $(z^2 - 3z)\cos 4z$.
5. $(z + 4i)^{i-2z}$.
6. $(z^2 + 2z)^{\cos z}$.
7. $\frac{z^2 - 3}{\operatorname{sh} 2z}$.
8. $\frac{\operatorname{ctg}^5 7z}{\ln(z + 3)}$.
9. $\arcsin\left(\frac{3z - 7i}{z^2 + i}\right)$.

10. Suppose $w^4 - 5z^2w^2 + 4\sin z = 0$. Find $\frac{dw}{dz}$.

In Exercises 11 to 19 evaluate

11. $\lim_{z \rightarrow 1} \frac{z^{10} - 1}{z^6 - 1}$.
12. $\lim_{z \rightarrow 2} \frac{z^2 - 4}{z^2 + z - 6}$.
13. $\lim_{z \rightarrow 3i} \frac{z^2 + 9}{z - 3i}$.
14. $\lim_{z \rightarrow 0} \frac{\cos 4z - \cos z}{3z^2}$.
15. $\lim_{z \rightarrow 0} \frac{1 - \cos z}{z \operatorname{tg} z}$.
16. $\lim_{z \rightarrow \infty} \frac{e^z}{z^2}$.
17. $\lim_{z \rightarrow \infty} \frac{5z^2 + z - 4}{z^2 + z - 6}$.
18. $\lim_{z \rightarrow \infty} (z - 2i)^{z+i}$.
19. $\lim_{z \rightarrow \frac{\pi}{2}} (\operatorname{ctg} z)^{\operatorname{tg} z}$.

4 Complex Integration and Cauchy's Theorem. Cauchy's Integral Formulas

4.1 Complex Line Integrals

Let $f(z)$ be continuous at all points of a curve C [Fig.14], which we shall assume has a

finite length, i.e., C is a rectifiable curve.

Subdivide C into n parts by means of points $z_0, z_1, z_2, \dots, z_{n-1}, z_n$, chosen arbitrarily, and call $z_0 = a, b = z_n$. On each arc joining z_{k-1} to z_k [where k goes from 1 to n], choose a point ξ_k . Form the sum

$$S_n = f(\xi_1)(z_1 - a) + \dots + f(\xi_n)(b - z_{n-1}) \quad (1)$$

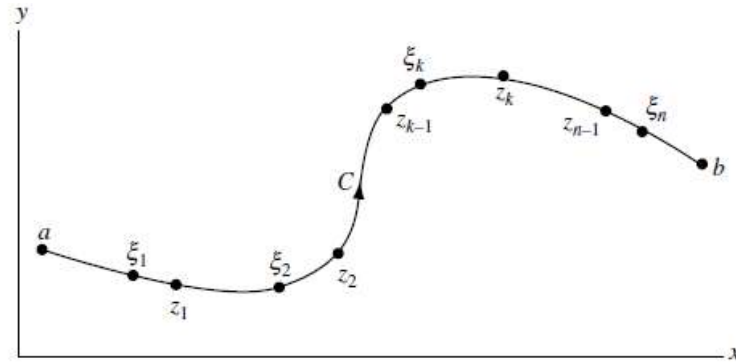

Fig.14

On writing $z_k - z_{k-1} = \Delta z_k$, this becomes

$$S_n = \sum_{k=1}^n f(\xi_k)(z_k - z_{k-1}) = \sum_{k=1}^n f(\xi_k)\Delta z_k \quad (2)$$

Let the number of subdivisions n increase in such a way that the largest of the chord lengths Δz_k approaches zero. Then, since $f(z)$ is continuous, the sum S_n approaches a limit that does not depend on the mode of subdivision and we denote this limit by

$$\int_a^b f(z)dz \quad \text{or} \quad \int_C f(z)dz \quad (3)$$

called the complex line integral or simply line integral of $f(z)$ along curve C , or the definite integral of $f(z)$ from a to b along curve C . In such a case, $f(z)$ is said to be integrable along C . If $f(z)$ is analytic at all points of a region \mathbb{R} and if C is a curve lying in \mathbb{R} , then $f(z)$ is continuous and therefore integrable along C .

Suppose $f(z) = u(x, y) + iv(x, y)$. Then the complex line integral (3) can be expressed in terms of real line integrals as follows

$$\begin{aligned} \int_{\gamma} f(z)dz &= \int_{\gamma} (u(x, y) + iv(x, y))(dx + i dy) = \\ &= \int_{\gamma} (u(x, y)dx - v(x, y)dy) + i \int_{\gamma} (v(x, y)dx - u(x, y)dy) \end{aligned} \quad (4)$$

For this reason, (4) is sometimes taken as a definition of a complex line integral.

Suppose $f(z)$ and $g(z)$ are integrable along C . Then the following hold:

Properties of the Integral

1. $\int_C f(z)dz = - \int_C f(z)dz$.

$$2. \int_a^b f(z)dz = \int_a^c f(z)dz + \int_c^b f(z)dz, c \in C.$$

$$3. \int_C (f(z) \pm g(z))dz = \int_C f(z)dz \pm \int_C g(z)dz.$$

$$4. \int_C Af(z)dz = A \int_C f(z)dz, A = \text{const}.$$

Let $z = z(t), \begin{cases} x = x(t), \\ y = y(t), \end{cases} \alpha \leq t \leq \beta$ be a continuous function of a complex variable

$t = u + iv$. Suppose that curve C in the z plane corresponds to curve C' in the z plane and that the derivative $z'(t)$ is continuous on C' . Then

$$\int_C f(z)dz = \int_{\alpha}^{\beta} f(z(t)) \cdot z'(t) dt = \int_{C'} f(z(t)) \cdot z'(t) dt \quad (5)$$

These conditions are certainly satisfied if z is analytic in a region containing curve C' .

Example 18 Evaluate $\int_C \bar{z}dz$ from $z = 0$ to $z = 4 + 2i$ along the curve C given by:

(a) $z = t^2 + it$, (b) the line from $z = 0$ to $z = 2i$.

Solution

(a) The points $z = 0$ and $z = 4 + 2i$ on C correspond to $t = 0$ and $t = 2$, respectively.

Then, the line integral equals

$$\int_0^2 (t^2 - it)d(t^2 + it) = \int_0^2 (t^2 - it)(2t + i)dt = \int_0^2 (2t^3 - it^2 + t)dt = 10 - \frac{8i}{3}.$$

(b) The given line integral equals

$$\int_C (x - iy)(dx + idy) = \int_C xdx + ydy + i \int_C xdy - ydx.$$

The line from $z = 0$ to $z = 2i$ is the same as the line from $(0, 0)$ to $(0, 2)$ for which $x = 0$, $dx = 0$ and the line integral equals

$$\int_0^2 ydy + i \int_0^2 0dy = \int_0^2 ydy = 2.$$

A region \mathbb{R} is called *simply-connected* if any simple closed curve, which lies in \mathbb{R} , can be shrunk to a point without leaving \mathbb{R} . A region \mathbb{R} , which is not simply-connected, is called *multiply-connected*.

For example, suppose \mathbb{R} is the region defined by $|z| < 2$ shown shaded in Fig.15. If Γ is any simple closed curve lying in \mathbb{R} [i.e., whose points are in \mathbb{R}], we see that it can be shrunk to a point that lies in \mathbb{R} , and thus does not leave \mathbb{R} , so that \mathbb{R} is simply-connected. On the

other hand, if \mathbb{R} is the region defined by $1 < |z| < 2$, shown shaded in Fig.16, then there is a simple closed curve Γ lying in \mathbb{R} that cannot possibly be shrunk to a point without leaving \mathbb{R} , so that \mathbb{R} is multiply-connected.

Intuitively, a simply-connected region is one that does not have any “holes” in it, while a multiply-connected region is one that does. The multiply-connected regions of Figs.15 and 16 have, respectively, one and three holes in them.

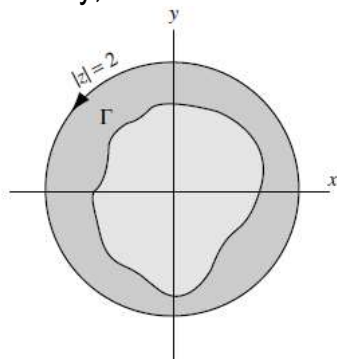

Fig.15

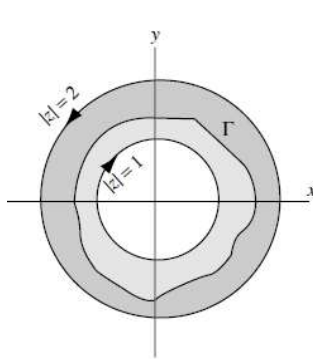

Fig.16

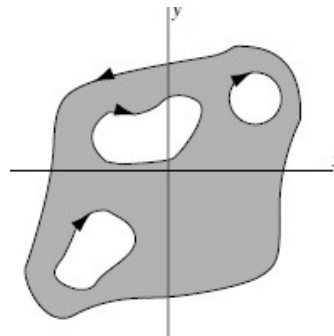

Fig.17

Any continuous, closed curve that does not intersect itself and may or may not have a finite length, is called a Jordan curve. An important theorem that, although very difficult to prove, seems intuitively obvious is the following.

Jordan Curve Theorem. A Jordan curve divides the plane into two regions having the curve as a common boundary. That region, which is bounded [i.e., is such that all points of it satisfy $|z| < M$ where M is some positive constant], is called the *interior* or *inside* of the curve, while the other region is called the *exterior* or *outside* of the curve.

Using the Jordan curve theorem, it can be shown that the region inside a simple closed curve is a simply-connected region whose boundary is the simple closed curve.

The boundary C of a region is said to be traversed in the *positive sense* or *direction* if an observer travelling in this direction [and perpendicular to the plane] has the region to the left. This convention leads to the directions indicated by the arrows in Figs.15, 16, and 17. We use the special symbol

$$\oint_C f(z)dz$$

to denote integration of $f(z)$ around the boundary C in the positive sense. In the case of a circle [Fig.15], the positive direction is the *counterclockwise direction*. The integral around C is often called a *contour integral*.

Let $f(z)$ be analytic in a region \mathbb{R} and on its boundary C . Then

$$\oint_C f(z)dz = 0 \tag{6}$$

This fundamental theorem, often called *Cauchy's integral theorem* or *simply Cauchy's theorem*, is valid for both simply- and multiply-connected regions. It was first proved by use of Green's theorem with the added restriction that $f'(z)$ be continuous in \mathbb{R} .

Let $f(z)$ be continuous in a simply-connected region \mathbb{R} and suppose that

$$\oint_C f(z) dz = 0$$

around every simple closed curve C in \mathbb{R} . Then $f(z)$ is analytic in \mathbb{R} .

This theorem, due to Morera, is often called the *converse of Cauchy's theorem*. It can be extended to multiply-connected regions. For a proof, which assumes that $f'(z)$ is continuous in \mathbb{R} .

Example 19 Evaluate $\oint_C \frac{dz}{z-a}$ where C is any simple closed curve C and $z = a$ is (a) outside C , (b) inside C .

Solution

(a) If a is outside C , then $f(z) = \frac{1}{z-a}$ is analytic everywhere inside and on C . Hence,

by Cauchy's theorem $\oint_C \frac{dz}{z-a} = 0$.

(b) Suppose a is inside C and let Γ be a circle of radius ϵ with center at $z = a$ so that Γ is inside C (this can be done since $z = a$ is an interior point).

$$\oint_C \frac{dz}{z-a} = \oint_{\Gamma} \frac{dz}{z-a} \quad (7)$$

Now on Γ , $|z-a| = \epsilon$ or $z-a = \epsilon e^{i\varphi}$, i.e., $z = a + \epsilon e^{i\varphi}$, $0 \leq \varphi < 2\pi$. Thus, since $dz = i\epsilon e^{i\varphi} d\varphi$, the right side of (7) becomes

$$\int_0^{2\pi} \frac{i\epsilon e^{i\varphi} d\varphi}{\epsilon e^{i\varphi}} = i \int_0^{2\pi} d\varphi = 2\pi i$$

which is the required value.

Suppose $f(z)$ and $F(z)$ are analytic in a region \mathbb{R} and such that $F'(z) = f(z)$. Then $F(z)$ is called an indefinite integral or anti-derivative of $f(z)$ denoted by

$$F(z) = \int f(z) dz + C \quad (8)$$

Just as in real variables, any two indefinite integrals differ by a constant. For this reason, an arbitrary constant C is often added to the right of (8).

Table of Indefinite Integrals

$\int z^n dz = \frac{z^{n+1}}{n+1}, n \neq -1.$	$\int \frac{dz}{z} = \ln z.$
$\int a^z dz = \frac{a^z}{\ln a}.$	$\int e^z dz = e^z.$
$\int \cos z dz = \sin z.$	$\int \sin z dz = -\cos z.$
$\int \frac{dz}{\cos^2 z} = \operatorname{tg} z.$	$\int \frac{dz}{\sin^2 z} = -\operatorname{ctg} z.$

$\int \frac{dz}{z^2 - a^2} = \frac{1}{2a} \ln \left \frac{z-a}{z+a} \right .$	$\int \frac{dz}{\sqrt{z^2 \pm a^2}} = \ln \left z + \sqrt{z^2 \pm a^2} \right .$
$\int \frac{dz}{z^2 + a^2} = \frac{1}{a} \operatorname{arctg} \frac{z}{a}.$	$\int \frac{dz}{\sqrt{a^2 - z^2}} = \arcsin \frac{z}{a}.$
$\int \operatorname{sh} z dz = \operatorname{ch} z.$	$\int \operatorname{ch} z dz = \operatorname{sh} z.$

Example 20 Determine

(a) $\int \sin z \sin 3z \sin 2z dz,$

(b) $\int z^2 \sqrt{4 + z^3} dz$

Solution

$$\begin{aligned} \text{(a)} \quad & \int \sin z \sin 3z \sin 2z dz = \frac{1}{2} \int (\cos 2z - \cos 4z) \sin 2z dz = \\ & = \frac{1}{2} \int \cos 2z \sin 2z dz - \frac{1}{2} \int \cos 4z \sin 2z dz = \frac{1}{4} \int \sin 4z dz - \frac{1}{4} \int (\sin 6z - \sin 2z) dz = \\ & = -\frac{\cos 4z}{16} + \frac{\cos 6z}{24} - \frac{\cos 2z}{8} + C. \end{aligned}$$

$$\begin{aligned} \text{(b)} \quad & \int z^2 \sqrt{4 + z^3} dz = \frac{1}{3} \int (4 + z^3)^{\frac{1}{2}} (4 + z^3)' dz = \frac{1}{3} \int (4 + z^3)^{\frac{1}{2}} d(4 + z^3) = \\ & = \frac{2}{9} (4 + z^3)^{\frac{3}{2}} + C = \frac{2}{9} \sqrt{(4 + z^3)^3} + C. \end{aligned}$$

THEOREM Suppose a and b are any two points in \mathbb{R} and $F'(z) = f(z)$. Then

$$\int_a^b f(z) dz = F(b) - F(a). \tag{9}$$

This can also be written in the form, familiar from elementary calculus

$$\int_a^b F'(z) dz = (F(z)) \Big|_a^b = F(b) - F(a). \tag{10}$$

Example 21 Calculate $I = \int_e^{e^2} z \ln z dz$.

Solution Using the formula for integration by parts we get

$$\begin{aligned} I &= \left| \begin{array}{l} u = \ln z, \quad du = \frac{dz}{z} \\ dv = z dz, \quad v = \frac{z^2}{2} \end{array} \right| = \left(\frac{z^2}{2} \ln z \right) \Big|_e^{e^2} - \int_e^{e^2} \frac{z^2 dz}{2z} = \frac{e^4}{2} \cdot 2 - \frac{e^2}{2} - \left(\frac{z^2}{4} \right) \Big|_e^{e^2} = \\ &= e^4 - \frac{e^2}{2} - \frac{e^4}{4} + \frac{e^2}{4} = \frac{1}{4} (3e^4 - e^2) \approx 39,10. \end{aligned}$$

THEOREM Let $f(z)$ be analytic in a region bounded by two simple closed curves C and

C_1 [where C_1 lies inside C as in Fig.18(a)] and on these curves. Then

$$\oint_C f(z)dz = \oint_{C_1} f(z)dz$$

where C and C_1 are both traversed in the positive sense relative to their interiors [counterclockwise in Fig.18(a)].

The result shows that if we wish to integrate $f(z)$ along curve C , we can equivalently replace C by any curve C_1 so long as $f(z)$ is analytic in the region between C and C_1 as in Fig.18(a).

THEOREM Let $f(z)$ be analytic in a region bounded by the non-overlapping simple closed curves C, C_1, C_2, \dots, C_n where C_1, \dots, C_n are inside C [as in Fig.18(b)] and on these curves. Then

$$\oint_C f(z)dz = \oint_{C_1} f(z)dz + \oint_{C_2} f(z)dz + \oint_{C_3} f(z)dz + \dots + \oint_{C_n} f(z)dz.$$

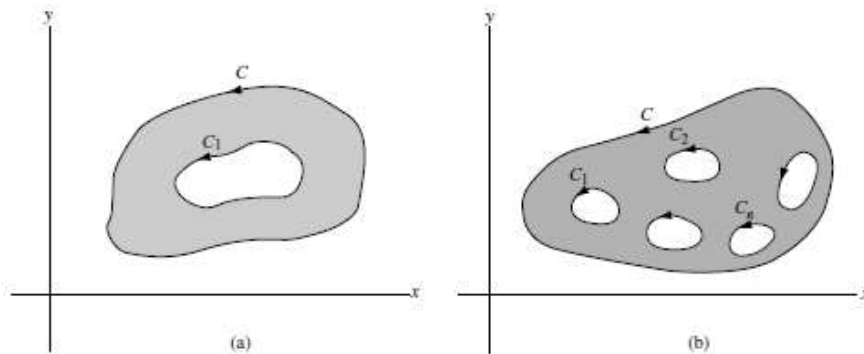

Fig.18

Exercise Set 5

In Exercises 1 to 9 evaluate

1. $\int_{1+i}^{2i} (z^3 + z) e^{\frac{z^2}{2}} dz.$

2. $\int_0^i z \sin z dz.$

3. $\int_{\gamma} (3 - 2z^2 + \sin z) dz, \quad \gamma: (|z|=2, \text{Im } z \geq 0).$

4. $\int_{\gamma} (z^3 + \cos z) dz, \quad \gamma: (|z|=1, \text{Re } z \geq 0).$

5. $\int_0^i z \cos z dz.$

6. $\int_{\gamma} (3z^2 + 2z) dz, \quad \gamma - \text{the line from } z = 1 - i \text{ to } z = 2i.$

$$7. \int_{\gamma} (\sin iz + z) dz, \quad \gamma: (|z|=1, \operatorname{Re} z \geq 0).$$

$$8. \int_{\gamma} z \cdot \bar{z} dz, \quad \gamma: (|z|=1, \operatorname{Im} z \leq 0).$$

$$9. \int_{\gamma} \bar{z}^2 dz, \quad \gamma - \text{the line from } z=0 \text{ to } z=2i.$$

In Exercises 10 to 18 determine

$$10. \int \sqrt{\sin z} \cos z dz.$$

$$11. \int \frac{dz}{\sin^2(1-3z)}.$$

$$12. \int \frac{dz}{2z^2 + 6z + 4}.$$

$$13. \int \frac{z^3 dz}{\sqrt{5+z^4}}.$$

$$14. \int \frac{dz}{\cos^2(3z+2)}.$$

$$15. \int z^3 e^{-z^2} dz.$$

$$16. \int (5z^2 + 1)e^{-2z} dz.$$

$$17. \int \frac{dz}{1 + \sqrt{z+3}}.$$

$$18. \int \sin^7 z \cos^5 z dz.$$

4.2 Cauchy's Integral Formulas

Let $f(z)$ be analytic inside and on a simple closed curve C and let a be any point inside C [Fig.19]. Then

$$\frac{1}{2\pi i} \oint_C \frac{f(z)}{z-a} dz = f(a) \quad (1)$$

where C is traversed in the positive (counterclockwise) sense.

Also, the n -th derivative of $f(z)$ at $z = a$ is given by

$$f^{(n)}(a) = \frac{n!}{2\pi i} \oint_C \frac{f(z)}{(z-a)^{n+1}} dz, \quad n \geq 1 \quad (2)$$

The result (1) can be considered a special case of (2) with $n = 0$ if we define $0! = 1$.

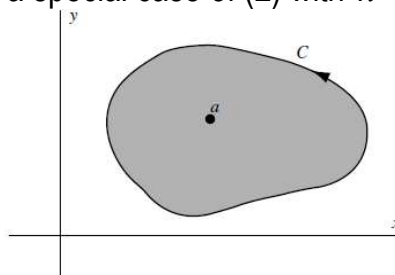

Fig.19

The results (1) and (2) are called Cauchy's integral formulas and are quite remarkable because they show that if a function $f(z)$ is known on the simple closed curve C , then the values of the function and all its derivatives can be found at all points inside C . Thus, if a function of a complex variable has a first derivative, i.e., is analytic, in a simply-connected region \mathbb{R} , all its higher derivatives exist in \mathbb{R} . This is not necessarily true for functions of real variables.

The following is a list of some important theorems that are consequences of Cauchy's integral formulas.

1. Morera's theorem (converse of Cauchy's theorem)

If $f(z)$ is continuous in a simply-connected region \mathbb{R} and if $\oint_C f(z)dz = 0$ around every

simple closed curve C in \mathbb{R} , then $f(z)$ is analytic in \mathbb{R} .

2. Liouville's theorem

Suppose that for all z in the entire complex plane, (i) $f(z)$ is analytic and (ii) $f(z)$ is bounded, i.e., $|f(z)| < M$ for some constant M . Then $f(z)$ must be a constant.

3. Fundamental theorem of algebra

Every polynomial equation $P(z) = a_0 + a_1z + a_2z^2 + \dots + a_nz^n = 0$ with degree $n \geq 1$ and $a_n \neq 0$ has at least one root.

From this it follows that $P(z) = 0$ has exactly n roots, due attention being paid to multiplicities of roots.

4. Gauss' mean value theorem

Suppose $f(z)$ is analytic inside and on a circle C with center at a and radius r . Then $f(a)$ is the mean of the values of $f(z)$ on C , i.e.,

$$f(a) = \frac{1}{2\pi} \int_0^{2\pi} f(a + re^{i\varphi}) d\varphi \quad (3)$$

5. Maximum modulus theorem

Suppose $f(z)$ is analytic inside and on a simple closed curve C and is not identically equal to a constant. Then the maximum value of $|f(z)|$ occurs on C .

6. Minimum modulus theorem

Suppose $f(z)$ is analytic inside and on a simple closed curve C and $f(z) \neq 0$ inside C . Then $|f(z)|$ assumes its minimum value on C .

7. The argument theorem

Let $f(z)$ be analytic inside and on a simple closed curve C except for a finite number of poles inside C . Then

$$\frac{1}{2\pi i} \oint_C \frac{f'(z)}{f(z)} dz = N - P \quad (4)$$

where N and P are, respectively, the number of zeros and poles of $f(z)$ inside C .

Example 22 Evaluate

$$(a) \oint_C \frac{\sin \pi z^2 + \cos \pi z^2}{(z-1)(z-2)} dz, \quad (b) \oint_C \frac{e^{2z}}{(z+1)^4} dz \text{ where } C \text{ is the circle } |z| = 3.$$

Solution (a) Since $\frac{1}{(z-1)(z-2)} = \frac{1}{z-2} - \frac{1}{z-1}$, we have

$$\oint_C \frac{\sin \pi z^2 + \cos \pi z^2}{(z-1)(z-2)} dz = \oint_C \frac{\sin \pi z^2 + \cos \pi z^2}{(z-2)} dz - \oint_C \frac{\sin \pi z^2 + \cos \pi z^2}{(z-1)} dz.$$

By Cauchy's integral formula with $a = 2$ and $a = 1$, respectively, we have

$$\oint_C \frac{\sin \pi z^2 + \cos \pi z^2}{(z-1)(z-2)} dz.$$

$$\oint_C \frac{\sin \pi z^2 + \cos \pi z^2}{(z-2)} dz = 2\pi i (\sin \pi 2^2 + \cos \pi 2^2) = 2\pi i,$$

$$\oint_C \frac{\sin \pi z^2 + \cos \pi z^2}{(z-1)} dz = 2\pi i (\sin \pi 1^2 + \cos \pi 1^2) = -2\pi i,$$

since $z=1$ and $z=2$ are inside C and $\sin \pi z^2 + \cos \pi z^2$ is analytic inside C . Then, the required integral has the value $2\pi i - (-2\pi i) = 4\pi i$.

(b) Let $f(z) = e^{2z}$ and $a = -1$ in the Cauchy integral formula

$$f^{(n)}(a) = \frac{n!}{2\pi i} \oint_C \frac{f(z)}{(z-a)^{n+1}} dz. \quad (1)$$

If $n=3$ then $f'(z) = 2e^{2z}$, $f''(z) = 4e^{2z}$, $f'''(z) = 8e^{2z}$ and $f'''(-1) = 8e^{-2}$. Hence (1) becomes

$$8e^{-2} = \frac{3!}{2\pi i} \oint_C \frac{e^{2z}}{(z+1)^4} dz$$

from which we see that the required integral has the value $\frac{8\pi i e^{-2}}{3}$.

Exercise Set 6

In Exercises 1 to 12 evaluate

$$1. \frac{1}{2\pi i} \oint_{|z+1|=3} \frac{3z^2 + 2z + 4}{(z^2 + 4) \cdot \sin \frac{z}{2}} dz.$$

$$2. \oint_{|z|=1} \frac{3z^4 - 2z^3 + 5}{z^4} dz.$$

$$3. \frac{1}{2\pi i} \oint_{|z-2|=3} \frac{\cos^2 z + 1}{z(z-\pi)} dz.$$

$$4. \oint_{|z|=4} \frac{dz}{(z^2 + 9)(z+9)}.$$

$$5. \oint_{|z-3|=6} \frac{z dz}{(z-2)^3(z+4)}.$$

$$6. \oint_{\gamma} \frac{2 dz}{z^2(z-1)}, \quad \gamma: \left(|z-1-i| = \frac{5}{4} \right).$$

$$7. \oint_{|z-3|=1} \frac{\sin 3z + 2}{z^2(z-\pi)} dz.$$

$$8. \oint_{|z-1|=1} \frac{\cos \frac{\pi}{4} z}{(z^2 - 1)^2} dz.$$

$$9. \oint_{|z-1|=3} \frac{z}{z^2 - 2z + 3} dz.$$

$$10. \oint_{|z-\pi|=1} \frac{(z^2 + \pi)^2}{i \sin z} dz.$$

$$11. \oint_{|z|=1} \frac{e^{iz} - 1}{z^3} dz.$$

$$12. \oint_{|z|=1} \frac{2 + \sin z}{z(z+2i)} dz.$$

5 Infinite Series Taylor's and Laurent's Series. The Residue Theorem Evaluation of Integrals

5.1 Series of Functions. Power Series. Taylor's Theorem

From the sequence of functions $\{u_n(z)\}$, let us form a new sequence $\{S_n(z)\}$ defined by

$$S_1(z) = u_1(z),$$

$$S_2(z) = u_1(z) + u_2(z),$$

$$S_3(z) = u_1(z) + u_2(z) + u_3(z),$$

$$S_n(z) = u_1(z) + u_2(z) + u_3(z) + \dots + u_n(z) = \sum_{i=1}^n u_i(z),$$

where $S_n(z)$, called the n -th partial sum, is the sum of the first n terms of the sequence $\{u_n(z)\}$.

The sequence $\{S_n(z)\}$ is symbolized by

$$u_1(z) + u_2(z) + u_3(z) + \dots + u_n(z) + \dots = \sum_{n=1}^{\infty} u_n(z) \quad (1)$$

called an infinite series. If $\lim_{n \rightarrow \infty} S_n(z) = S(z)$, the series is called convergent and $S(z)$ is its

sum; otherwise, the series is called divergent. We sometimes write $\sum_{n=1}^{\infty} u_n(z)$ as $\sum u_n(z)$ or

$\sum u_n$ for brevity.

As we have already seen, a necessary condition that the series (1) converges is $\lim_{n \rightarrow \infty} a_n = 0$, but this is not sufficient.

If a series converges for all values of z (points) in a region \mathbb{R} , we call \mathbb{R} the *region of convergence* of the series.

A series $\sum_{n=1}^{\infty} u_n(z)$ is called *absolutely convergent* if the series of absolute values, i.e.,

$\sum_{n=1}^{\infty} |u_n(z)|$, converges.

If $\sum_{n=1}^{\infty} u_n(z)$ converges but $\sum_{n=1}^{\infty} |u_n(z)|$ does not converge, we call $\sum_{n=1}^{\infty} u_n(z)$ *conditionally convergent*.

A series having the form

$$\sum_{n=0}^{\infty} a_n (z-a)^n = a_0 + a_1(z-a) + a_2(z-a)^2 + \dots + a_n(z-a)^n + \dots \quad (2)$$

is called a power series in $z-a$. We shall sometimes shorten (2) to $\sum a_n (z-a)^n$.

Clearly the power series (2) converges for $z=a$, and this may indeed be the only point for which it converges. In general, however, the series converges for other points as well. In such

cases, we can show that there exists a positive number R such that (2) converges for $|z - a| < R$ and diverges for $|z - a| > R$, while for $|z - a| = R$, it may or may not converge.

Geometrically, if Γ is a circle of radius R with center at $z = a$, then the series (2) converges at all points inside Γ and diverges at all points outside Γ , while it may or may not converge on the circle Γ . We can consider the special cases $R = 0$ and $R = \infty$, respectively, to be the cases where (2) converges only at $z = a$ or converges for all (finite) values of z . Because of this geometrical interpretation, R is often called the radius of convergence of (2) and the corresponding circle is called the circle of convergence.

For reference purposes, we list here some important theorems involving sequences and series. Many of these will be familiar from their analogs for real variables.

THEOREM 1 Let $u_n = a_n + ib_n$, where a_n and b_n are real. Then, a necessary and sufficient condition that $\{u_n\}$ converges is that $\{a_n\}$ and $\{b_n\}$ converge.

THEOREM 2 A necessary condition that $\sum u_n$ converges is that $\lim_{n \rightarrow \infty} u_n = 0$. However, the condition is not sufficient.

THEOREM 3 Multiplication of each term of a series by a constant different from zero does not affect the convergence or divergence. Removal (or addition) of a finite number of terms from (or to) a series does not affect the convergence or divergence.

THEOREM 4 A necessary and sufficient condition that $\sum (a_n + ib_n)$ converges, where a_n and b_n are real, is that $\sum a_n$ and $\sum b_n$ converge.

THEOREM 5 If $\sum |u_n|$ converges, then $\sum u_n$ converges. In words, an absolutely convergent series is convergent.

THEOREM 6 The terms of an absolutely convergent series can be rearranged in any order and all such rearranged series converge to the same sum. Also, the sum, difference, and product of absolutely convergent series is absolutely convergent.

THEOREM 7 (*Comparison tests*)

(a) If $\sum |v_n|$ converges and $|u_n| \leq |v_n|$, then $\sum u_n$ converges absolutely.

(b) If $\sum |v_n|$ diverges and $|u_n| \geq |v_n|$, then $\sum |u_n|$ diverges but $\sum u_n$ may or may not converge.

THEOREM 8 (*Ratio test*) Let $\lim_{n \rightarrow \infty} \left| \frac{u_{n+1}}{u_n} \right| = L$. Then $\sum u_n$ converges (absolutely) if $L < 1$ and diverges if $L > 1$. If $L = 1$, the test fails.

THEOREM 9 (*n-th Root test*) Let $\lim_{n \rightarrow \infty} \sqrt[n]{|u_n|} = L$. Then $\sum u_n$ converges (absolutely) if $L < 1$ and diverges if $L > 1$. If $L = 1$, the test fails.

THEOREM 10 (*Integral test*) If $f(x) \geq 0$ for $x \geq a$, then $\sum f(n)$ converges or diverges

according as $\lim_{M \rightarrow \infty} \int_a^M f(x) dx$ converges or diverges.

THEOREM 11 A power series converges uniformly and absolutely in any region that lies entirely inside its circle of convergence.

THEOREM 12 (a) A power series can be differentiated term by term in any region that lies entirely inside its circle of convergence.

(b) A power series can be integrated term by term along any curve C that lies entirely inside its circle of convergence.

(c) The sum of a power series is continuous in any region that lies entirely inside its circle of convergence.

Example 23 Find the region of convergence of the series $\sum_{n=1}^{\infty} \frac{(z+2)^{n-1}}{4^n \cdot (n+1)^3}$.

Solution

If $u_n = \frac{(z+2)^{n-1}}{4^n \cdot (n+1)^3}$, then $u_{n+1} = \frac{(z+2)^n}{4^{n+1} \cdot (n+2)^3}$. Hence, excluding $z = -2$ for which the given series converges, we have

$$\lim_{n \rightarrow \infty} \left| \frac{u_{n+1}}{u_n} \right| = \lim_{n \rightarrow \infty} \left| \frac{(z+2)}{4} \cdot \frac{(n+1)^3}{(n+2)^3} \right| = \frac{|z+2|}{4}.$$

Then the series converges (absolutely) for $\frac{|z+2|}{4} < 1$, i.e., $|z+2| < 4$. The point $z = -2$ is included in $|z+2| < 4$.

If $\frac{|z+2|}{4} = 1$, i.e., $|z+2| = 4$, the ratio test fails. However, it is seen that in this case

$$\left| \frac{(z+2)^{n-1}}{4^n \cdot (n+1)^3} \right| = \frac{1}{4(n+1)^3} \leq \frac{1}{n^3}$$

and since $\sum \frac{1}{n^3}$ converges [α series with $\alpha = 3$], the given series converges (absolutely).

It follows that the given series converges (absolutely) for $|z+2| \leq 4$. Geometrically, this is the set of all points inside and on the circle of radius 4 with center at $z = -2$, called the circle of convergence [shown shaded in Fig.20]. The radius of convergence is equal to 4.

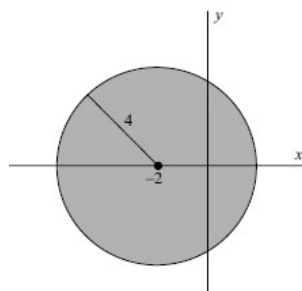

Fig.21

Let $f(z)$ be analytic inside and on a simple closed curve C .

$$f(z) = f(a) + f'(a) \cdot (z-a) + \frac{f''(a)}{2!} (z-a)^2 + \dots + \frac{f^{(n)}(a)}{n!} (z-a)^n + \dots \quad (3)$$

This is called Taylor's theorem and the series (3) is called a Taylor series or expansion for $f(z)$.

The region of convergence of the series (3) is given by $|z - a| < R$, where the radius of convergence R is the distance from a to the nearest singularity of the function $f(z)$. On $|z - a| = R$, the series may or may not converge. For $|z - a| > R$, the series diverges.

If the nearest singularity of $f(z)$ is at infinity, the radius of convergence is infinite, i.e., the series converges for all z . If $a = 0$ in (3), the resulting series is often called a Maclaurin series.

The following list shows some special series together with their regions of convergence. In the case of multiple-valued functions, the principal branch is used.

$$e^z = 1 + z + \frac{z^2}{2!} + \frac{z^3}{3!} + \dots + \frac{z^n}{n!} + \dots, |z| < \infty.$$

$$\sin z = z - \frac{z^3}{3!} + \frac{z^5}{5!} - \dots + (-1)^{n-1} \frac{z^{2n-1}}{(2n-1)!} + \dots, |z| < \infty.$$

$$\cos z = 1 - \frac{z^2}{2!} + \frac{z^4}{4!} - \dots + (-1)^{n-1} \frac{z^{2n-2}}{(2n-2)!} + \dots, |z| < \infty.$$

$$\frac{1}{1-z} = 1 + z + z^2 + \dots + z^{n-1} + \dots, |z| < 1.$$

$$\ln(1+z) = z - \frac{z^2}{2} + \frac{z^3}{3} - \dots + (-1)^{n-1} \frac{z^n}{n} + \dots, |z| < 1.$$

$$(1+z)^\alpha = 1 + \alpha z + \frac{\alpha(\alpha-1)}{2!} z^2 + \dots + \frac{\alpha(\alpha-1)\dots(\alpha-n+1)}{n!} z^n + \dots, |z| < 1.$$

5.2 Laurent's Theorem. Classification of Singularities

Let C_1 and C_2 be concentric circles of radii R_1 and R_2 , respectively, and center at a [Fig.22]. Suppose that $f(z)$ is single-valued and analytic on C_1 and C_2 and, in the ring-shaped region \mathbb{R} [also called the annulus or annular region] between C_1 and C_2 , is shown shaded in Fig.22. Let $a + h$ be any point in \mathbb{R} . Then we have

$$f(a+h) = a_0 + a_1 h + \dots + \frac{a_{-1}}{h} + \frac{a_{-2}}{h^2} + \dots \quad (1)$$

where

$$a_n = \frac{1}{2\pi i} \oint_{C_1} \frac{f(z)}{(z-a)^{n+1}} dz, \quad n \geq 0,$$

$$a_{-n} = \frac{1}{2\pi i} \oint_{C_1} (z-a)^{n-1} f(z) dz, \quad n \geq 1 \quad (2)$$

C_1 and C_2 being traversed in the positive direction with respect to their interiors.

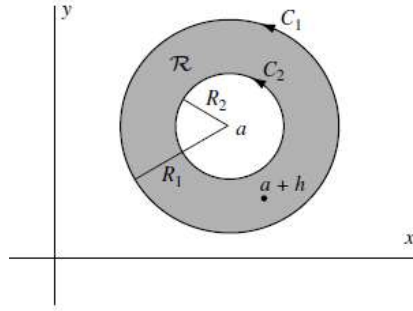

Fig.22

In the above integrations, we can replace C_1 and C_2 by any concentric circle C between C_1 and C_2 . Then, the coefficients (2) can be written in a single formula,

$$a_n = \frac{1}{2\pi i} \oint_C \frac{f(z)}{(z-a)^{n+1}} dz, \quad n \in \mathbb{Z} \quad (3)$$

With an appropriate change of notation, we can write the above as

$$f(z) = a_0 + a_1(z-a) + a_2(z-a)^2 + \dots + \frac{a_{-1}}{z-a} + \frac{a_{-2}}{(z-a)^2} + \dots \quad (4)$$

where

$$a_n = \frac{1}{2\pi i} \oint_C \frac{f(t)}{(t-a)^{n+1}} dt, \quad n \in \mathbb{Z} \quad (5)$$

This is called Laurent's theorem and (1) or (4) with coefficients (2), (3), or (5) is called a Laurent series or expansion.

The part $a_0 + a_1(z-a) + a_2(z-a)^2 + \dots$ is called the analytic part of the Laurent series, while the remainder of the series, which consists of inverse powers of $z-a$, is called the principal part. If the principal part is zero, the Laurent series reduces to a Taylor series.

It is possible to classify the singularities of a function $f(z)$ by examination of its Laurent series. For this purpose, we assume that in Fig.21, $R_2 = 0$, so that $f(z)$ is analytic inside and on C_1 except at $z = a$, which is an isolated singularity. In the following, all singularities are assumed isolated unless otherwise indicated.

1. Poles. If $f(z)$ has the form (4) in which the principal part has only a finite number of terms given by

$$\frac{a_{-1}}{z-a} + \frac{a_{-2}}{(z-a)^2} + \dots + \frac{a_{-n}}{(z-a)^n}$$

where $a_{-n} \neq 0$, then $z = a$ is called a *pole of order n*. If $n = 1$, it is called a *simple pole*.

If $f(z)$ has a pole at $z = a$, then $\lim_{z \rightarrow a} f(z) = \infty$.

2. Removable singularities. If a single-valued function $f(z)$ is not defined at $z = a$ but $\lim_{z \rightarrow a} f(z)$ exists, then $z = a$ is called a *removable singularity*. In a such case, we define $f(z)$ at $z = a$ as equal to $\lim_{z \rightarrow a} f(z)$, and $f(z)$ will then be analytic at a .

Example 24 If $f(z) = \frac{\sin z}{z}$, then $z = 0$ is a removable singularity since $f(0)$ is not defined but

$$\lim_{z \rightarrow 0} \frac{\sin z}{z} = 1. \text{ We define } f(0) = \lim_{z \rightarrow 0} \frac{\sin z}{z} = 1. \text{ Note that in this case}$$

$$\frac{\sin z}{z} = \frac{1}{z} \left(z - \frac{z^3}{3!} + \frac{z^5}{5!} - \dots + (-1)^{n-1} \frac{z^{2n-1}}{(2n-1)!} + \dots \right) = 1 - \frac{z^2}{3!} + \frac{z^4}{5!} - \dots$$

3. Essential singularities. If $f(z)$ is single-valued, then any singularity that is not a pole or removable singularity is called an essential singularity. If $z = a$ is an essential singularity of $f(z)$, the principal part of the Laurent expansion has infinitely many terms.

Example 25 Since $e^{\frac{1}{z}} = 1 + \frac{1}{z} + \frac{1}{2!z^2} + \frac{1}{3!z^3} + \dots$, $z = 0$ is an essential singularity.

4. Branch points. A point $z = z_0$ is called a *branch point* of a multiple-valued function $f(z)$ if the branches of $f(z)$ are interchanged when z describes a closed path about z_0 . A branch point is a non-isolated singularity. Since each of the branches of a multiple-valued function is analytic, all of the theorems for analytic functions, in particular Taylor's theorem, apply.

Example 26 The branch of $f(z) = z^{\frac{1}{2}}$, which has the value 1 for $z = 1$, has a Taylor series of the form $a_0 + a_1(z-1) + a_2(z-1)^2 + \dots$ radius of convergence $R = 1$ [the distance from $z = 1$ to the nearest singularity, namely the branch point $z = 0$].

5. Singularities at infinity. By letting $z = \frac{1}{w}$ in $f(z)$, we obtain the function $f\left(\frac{1}{w}\right) = F(w)$. Then the nature of the singularity for $f(z)$ at $z = \infty$ [the point at infinity] is defined to be the same as that of $F(w)$ at $w = 0$.

Example 27 $f(z) = z^3$ has a pole of order 3 at $z = \infty$, since $f\left(\frac{1}{w}\right) = F(w) = \frac{1}{w^3}$ has a pole of order 3 at $w = 0$. Similarly, $f(z) = e^z$ has an essential singularity at $z = \infty$, since $f\left(\frac{1}{w}\right) = F(w) = e^{\frac{1}{w}}$ has an essential singularity at $w = 0$.

Example 28 Find Laurent series about the indicated singularity for each of the following functions:

$$(a) \frac{e^{2z}}{(z-1)^3}, z = 1; \quad (b) \frac{z - \sin z}{z^3}, z = 0; \quad (c) \frac{1}{z^2(z-3)^2}, z = 3.$$

Name the singularity in each case and give the region of convergence of each series.

Solution

(a) Let $z - 1 = u$. Then $z = u + 1$ and

$$\frac{e^{2z}}{(z-1)^3} = \frac{e^{2u+2}}{u^3} = \frac{e^2}{u^3} e^{2u} = \frac{e^2}{u^3} \left(1 + 2u + \frac{(2u)^2}{2!} + \frac{(2u)^3}{3!} + \frac{(2u)^4}{4!} + \dots \right) =$$

$$= \frac{e^2}{(z-1)^3} + \frac{2e^2}{(z-1)^2} + \frac{2e^2}{(z-1)} + \frac{4e^2}{3} + \frac{2e^2}{3}(z-1) + \dots$$

$z=1$ is a pole of order 3, or *triple pole*.

(b)

$$\frac{z - \sin z}{z^3} = \frac{z - \left(z - \frac{z^3}{3!} + \frac{z^5}{5!} - \frac{z^7}{7!} + \dots \right)}{z^3} = \frac{1}{z^3} \left(\frac{z^3}{3!} - \frac{z^5}{5!} + \frac{z^7}{7!} + \dots \right) = \frac{1}{3!} - \frac{z^2}{5!} + \frac{z^5}{7!} + \dots$$

$z=0$ is a *removable singularity*. The series converges for all values of z .

(c) Let $z-3 = u$. Then, by the binomial theorem,

$$\begin{aligned} \frac{1}{z^2(z-3)^2} &= \frac{1}{u^2(u+3)^2} = \frac{1}{9u^2 \left(1 + \frac{u}{3} \right)^2} = \\ &= \frac{1}{9u^2} \left(1 + (-2) \left(\frac{u}{3} \right) + \frac{(-2)(-3)}{2!} \left(\frac{u}{3} \right)^2 + \frac{(-2)(-3)(-4)}{3!} \left(\frac{u}{3} \right)^3 + \dots \right) = \\ &= \frac{1}{9u^2} - \frac{2}{27u} + \frac{1}{27} - \frac{4}{243}u + \dots = \frac{1}{9(z-3)^2} - \frac{2}{27(z-3)} + \frac{1}{27} - \frac{4}{243}(z-3) + \dots \end{aligned}$$

$z=3$ is a pole of order 2 or double pole.

Example 29 Expand $f(z) = \frac{1}{(z+1)(z+3)}$ in a Laurent series valid for:

(a) $1 < |z| < 3$, (b) $|z| > 3$, (c) $0 < |z+1| < 2$, (d) $|z| < 1$.

Solution

(a) Resolving into partial fractions,

$$\frac{1}{(z+1)(z+3)} = \frac{1}{2} \cdot \frac{1}{z+1} - \frac{1}{2} \cdot \frac{1}{z+3}.$$

If $|z| > 1$,

$$\frac{1}{2(z+1)} = \frac{1}{2z \left(1 + \frac{1}{z} \right)} = \frac{1}{2z} \left(1 - \frac{1}{z} + \frac{1}{z^2} - \frac{1}{z^3} + \frac{1}{z^4} + \dots \right) = \frac{1}{2z} - \frac{1}{2z^2} + \frac{1}{2z^3} - \dots$$

If $|z| < 3$,

$$\frac{1}{2(z+3)} = \frac{1}{6 \left(1 + \frac{z}{3} \right)} = \frac{1}{6} \left(1 - \frac{z}{3} + \frac{z^2}{9} - \frac{z^3}{27} + \dots \right) = \frac{1}{6} - \frac{z}{18} + \frac{z^2}{54} - \frac{z^3}{162} + \dots$$

Then, the required Laurent expansion valid for both $|z| > 1$ and $|z| < 3$, i.e., $1 < |z| < 3$, is

$$\dots - \frac{1}{2z^4} + \frac{1}{2z^3} - \frac{1}{2z^2} + \frac{1}{2z} - \frac{1}{6} + \frac{z}{18} - \frac{z^2}{54} + \frac{z^3}{162} - \dots$$

(b) If $|z| > 1$, we have as in part (a),

$$\frac{1}{2(z+1)} = \frac{1}{2z} - \frac{1}{2z^2} + \frac{1}{2z^3} - \dots$$

If $|z| > 3$,

$$\frac{1}{2(z+3)} = \frac{1}{2z\left(1 + \frac{3}{z}\right)} = \frac{1}{2z} \left(1 - \frac{3}{z} + \frac{9}{z^2} - \frac{27}{z^3} + \frac{81}{z^4} - \dots\right) = \frac{1}{2z} - \frac{3}{2z^2} + \frac{9}{2z^3} - \dots$$

Then, the required Laurent expansion valid for both $|z| > 1$ and $|z| > 3$, i.e., $|z| > 3$, is

$$\frac{1}{z^2} - \frac{4}{z^3} + \frac{13}{z^4} - \frac{40}{z^5} + \dots$$

(c) Let $z+1 = u$. Then

$$\begin{aligned} \frac{1}{(z+1)(z+3)} &= \frac{1}{u(u+2)} = \frac{1}{2u\left(1 + \frac{u}{2}\right)} = \frac{1}{2u} \left(1 - \frac{u}{2} + \frac{u^2}{4} - \frac{u^3}{8} + \dots\right) \\ &= \frac{1}{2(z+1)} - \frac{1}{4} + \frac{1}{8}(z+1) - \frac{1}{16}(z+1)^2 + \dots, \text{ valid for } 0 < |z+1| < 2. \end{aligned}$$

(d) If $|z| < 1$,

$$\frac{1}{2(z+1)} = \frac{1}{2(1+z)} = \frac{1}{2} (1 - z + z^2 - z^3 + z^4 - \dots) = \frac{1}{2} - \frac{1}{2}z + \frac{1}{2}z^2 - \frac{1}{2}z^3 + \dots$$

If $|z| < 3$, we have by part (a),

$$\frac{1}{2(z+3)} = \frac{1}{6} - \frac{z}{18} + \frac{z^2}{54} - \frac{z^3}{162} + \dots$$

Then the required Laurent expansion, valid for both $|z| < 1$ and $|z| < 3$, i.e., $|z| < 1$, is by subtraction

$$\frac{1}{3} - \frac{4}{9}z + \frac{13}{27}z^2 - \frac{40}{81}z^3 + \dots$$

This is a Taylor series.

Exercise Set 7

In Exercises 1 to 3 investigate the convergence of:

$$1. \sum_{n=1}^{\infty} \left(\frac{(-1)^n}{n} + i \frac{n}{3^n} \right). \quad 2. \sum_{n=1}^{\infty} \left(\frac{\cos 3n}{n^3} + \frac{\sin 4n}{n^4} \cdot i \right). \quad 3. \sum_{n=1}^{\infty} \left(\frac{1}{n^2} + i \frac{2n-1}{3n+1} \right).$$

In Exercises 4 to 7 find the region of convergence of:

$$4. \sum_{n=1}^{\infty} \frac{n+1}{2^n} (z-2+i)^n. \quad 5. \sum_{n=1}^{\infty} \frac{(n+1)!(4+3i)^n}{(2n+1)!} z^n$$

$$6. \sum_{n=0}^{\infty} \frac{3n+2}{(1+i\sqrt{3})^n} (z+2-i)^n. \quad 7. \sum_{n=0}^{\infty} \frac{(2n+1)}{(4+i)^n} (z-3+i)^n.$$

In Exercises 8 to 13 expand $f(z)$ in a Laurent series valid for given K :

8. $f(z) = \frac{1}{(z-2)(z-3)}$, $K: 2 < |z| < 3$;
9. $f(z) = \frac{2z-3}{z^2-3z+2}$, $K: 0 < |z-2| < 1$;
10. $f(z) = \frac{2}{(z-1)(z-3)}$, $K: 3 < |z-1| < +\infty$;
11. $f(z) = \frac{z+2}{z^2+2z-8}$, $K: 2 < |z+2| < 4$;
12. $f(z) = \frac{2z+3}{z^2+3z+2}$, $K: 1 < |z| < 2$;
13. $f(z) = \frac{2z-3}{z^2-3z+2}$, $K: |z-1| < 2$.

In Exercises 14 to 19 expand each of the following functions in a Laurent series at given point z_0 :

14. $f(z) = \ln \frac{z-3}{z}$, $z_0 = \infty$;
15. $f(z) = \sin \frac{z}{z-1}$, $z_0 = 1$;
16. $f(z) = \cos \frac{i}{z^2} + \frac{z}{z-1}$, $z_0 = 0$;
17. $f(z) = e^{\frac{z}{z-3}}$, $z_0 = 3$;
18. $f(z) = \frac{1}{z} \sin^2 \frac{2}{z}$, $z_0 = 0$;
19. $f(z) = \ln \frac{z-1}{z-2}$, $z_0 = \infty$;

In Exercises 20 to 27 determine and classify all the singularities of the functions

20. $f(z) = \frac{1 + \cos z}{z - \pi}$, $z_0 = \pi$.
21. $f(z) = \frac{e^{z+i}}{z+i}$, $z_0 = -i$.
22. $f(z) = \frac{\sin 4z - 4z}{e^z - 1 - z}$, $z_0 = 0$.
23. $f(z) = \frac{\sin z}{z^3(1 - \cos z)}$, $z_0 = 2\pi$.
24. $f(z) = \cos \frac{1}{\pi + z}$, $z_0 = -\pi$.
25. $f(z) = \frac{z^2 - 1}{z^6 + 2z^5 + z^4}$, $z_0 = -1$.
26. $f(z) = \frac{z^2 - 1}{z^6 + 2z^5 + z^4}$, $z_0 = 0$.
27. $f(z) = \frac{e^z - 1}{\sin \pi z}$, $z_0 = 0$.

5.3 Residues. Calculation of Residues. The Residue Theorem. Evaluation of Definite Integrals

Let $f(z)$ be single-valued and analytic inside and on a circle C except at the point $z = a$ chosen as the center of C . Then, as we have seen in Chapter 2.5.2, $f(z)$ has a Laurent series about $z = a$ given by

$$f(z) = \sum_{n=-\infty}^{\infty} a_n (z-a)^n = a_0 + a_1(z-a) + a_2(z-a)^2 + \dots + \frac{a_{-1}}{z-a} + \frac{a_{-2}}{(z-a)^2} + \dots \quad (1)$$

where

$$a_n = \frac{1}{2\pi i} \oint_C \frac{f(z)}{(z-a)^{n+1}} dz, \quad n \in \mathbb{Z} \quad (2)$$

In the special case $n = -1$, we have from (2)

$$\oint_C f(z) dz = 2\pi i a_{-1} \quad (3)$$

Formally, we can obtain (3) from (1) by integrating term by term and using the results

$$\oint_C \frac{dz}{(z-a)^n} = \begin{cases} 2\pi i, n = 1 \\ 0, n \neq 1 \end{cases} \quad (4)$$

Because of the fact that (3) involves only the coefficient a_{-1} in (1), we call a_{-1} the residue of $f(z)$ at $z = a$.

$$\operatorname{Res}_{z=a} f(z) = a_{-1} \quad (5)$$

To obtain the residue of a function $f(z)$ at $z = a$, it may appear from (1) that the Laurent expansion of $f(z)$ about $z = a$ must be obtained. However, in the case where $z = a$ is a pole of order k , there is a simple formula for a_{-1} given by

$$\operatorname{Res}_{z=a} f(z) = \frac{1}{(k-1)!} \lim_{z \rightarrow a} \left((z-a)^k f(z) \right)^{(k-1)}, \quad k \geq 1 \quad (6)$$

If $k = 1$ (simple pole), then the result is especially simple and is given by

$$\operatorname{Res}_{z=a} f(z) = a_{-1} = \lim_{z \rightarrow a} (z-a) f(z) \quad (7)$$

which is a special case of (6) with $k = 1$ if we define $0! = 1$.

Example 30 If $f(z) = \frac{z}{(z-1)(z+1)^2}$, then $z = 1$ and $z = -1$ are poles of orders one and two, respectively.

Solution

We have, using (7) and (7) with $k = 2$,

$$\operatorname{Res}_{z=1} f(z) = \lim_{z \rightarrow 1} (z-1) f(z) = \lim_{z \rightarrow 1} (z-1) \frac{z}{(z-1)(z+1)^2} = \lim_{z \rightarrow 1} \frac{z}{(z+1)^2} = \frac{1}{4},$$

$$\begin{aligned} \operatorname{Res}_{z=-1} f(z) &= \frac{1}{(2-1)!} \lim_{z \rightarrow -1} \left((z+1)^2 \frac{z}{(z-1)(z+1)^2} \right)' = \lim_{z \rightarrow -1} \left(\frac{z}{z-1} \right)' \\ &= \lim_{z \rightarrow -1} \frac{z-1-z}{(z-1)^2} = -\frac{1}{4}. \end{aligned}$$

If $z = a$ is an essential singularity, the residue can sometimes be found by using known series expansions.

Example 31 Let $f(z) = e^{-\frac{1}{z}}$. Then, $z = 0$ is an essential singularity and from the known expansion for e^u with $u = -\frac{1}{z}$, we find

$$e^{-\frac{1}{z}} = 1 - \frac{1}{z} + \frac{1}{2!z^2} - \frac{1}{3!z^3} + \dots$$

from which we see that the residue at $z = 0$ is the coefficient of $\frac{1}{z}$ and equals -1 .

Let $f(z)$ be single-valued and analytic inside and on a simple closed curve C except at the singularities a, b, c, \dots inside C , which have residues given by $a_{-1}, b_{-1}, c_{-1}, \dots$ [see Fig.22]. Then, the residue theorem states that

$$\oint_C f(z) dz = 2\pi i (a_{-1} + b_{-1} + c_{-1} + \dots) \quad (8)$$

i.e., the integral of $f(z)$ around C is $2\pi i$ times the sum of the residues of $f(z)$ at the singularities enclosed by C . Note that (8) is a generalization of (3). Cauchy's theorem and integral formulas are special cases of this theorem.

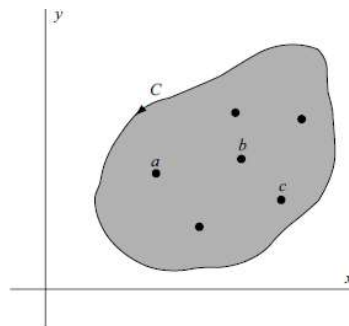

Fig.22

Example 32 Evaluate $\frac{1}{2\pi i} \oint_C \frac{e^{zt}}{z^2(z^2 + 2z + 2)} dz$ around the circle C with equation $|z| = 3$

Solution

The integrand $\frac{e^{zt}}{z^2(z^2 + 2z + 2)}$ has a double pole at $z = 0$ and two simple poles at $z = -1 \pm i$ [roots of $z^2 + 2z + 2 = 0$]. All these poles are inside C .

Residue at $z = 0$ is

$$\begin{aligned} \text{Res}_{z=0} f(z) &= \frac{1}{(2-1)!} \lim_{z \rightarrow 0} \left(z^2 \frac{e^{zt}}{z^2(z^2 + 2z + 2)} \right)' = \\ &= \lim_{z \rightarrow 0} \frac{(z^2 + 2z + 2)te^{zt} - e^{zt}(2z + 2)}{(z^2 + 2z + 2)^2} = \frac{t-1}{2}. \end{aligned}$$

Residue at $z = -1 + i$ is

$$\begin{aligned} \text{Res } f(z) &= \lim_{z \rightarrow -1+i} \left((z - (-1+i)) \frac{e^{zt}}{z^2(z^2 + 2z + 2)} \right) = \\ &= \lim_{z \rightarrow -1+i} \frac{e^{zt}}{z^2} \lim_{z \rightarrow -1+i} \frac{z+1-i}{z^2 + 2z + 2} = \frac{e^{(-1+i)t}}{4}. \end{aligned}$$

Residue at $z = -1 - i$ is

$$\begin{aligned} \text{Res } f(z) &= \lim_{z \rightarrow -1-i} \left((z - (-1-i)) \frac{e^{zt}}{z^2(z^2 + 2z + 2)} \right) = \\ &= \lim_{z \rightarrow -1-i} \frac{e^{zt}}{z^2} \lim_{z \rightarrow -1-i} \frac{z+1+i}{z^2 + 2z + 2} = \frac{e^{(-1-i)t}}{4}. \end{aligned}$$

Then, by the residue theorem

$$\frac{1}{2\pi i} \oint_C \frac{e^{zt}}{z^2(z^2 + 2z + 2)} dz = \frac{1}{2\pi i} 2\pi i \left(\frac{t-1}{2} + \frac{e^{(-1+i)t}}{4} + \frac{e^{(-1-i)t}}{4} \right) = \frac{t-1}{2} + \frac{1}{2} e^{-t} \cos t.$$

The evaluation of definite integrals is often achieved by using the residue theorem together with a suitable function $f(z)$ and a suitable closed path or contour C , the choice of which may require great ingenuity. The following types are most common in practice.

1. $\int_{-\infty}^{+\infty} F(x) dx$, where $F(x)$ is a rational function.

Consider $\int_C F(z) dz$ along a contour C consisting of the line along the x axis from $-R$ to $+R$ and the semicircle Γ above the x axis having this line as diameter [Fig.23]. Then, let

$R \rightarrow \infty$. If $F(x)$ is an even function, this can be used to evaluate $\int_0^{+\infty} F(x) dx$.

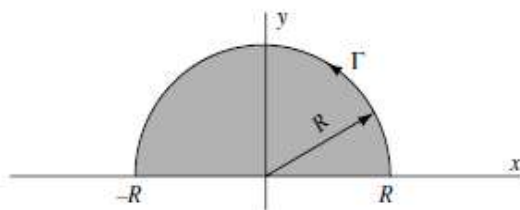

Fig.23

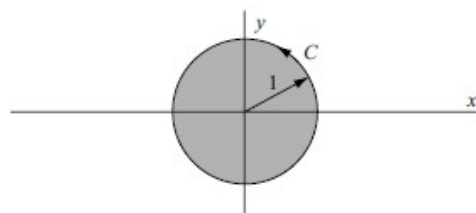

Fig.24

2. $\int_0^{2\pi} G(\sin \varphi, \cos \varphi) d\varphi$, where $G(\sin \varphi, \cos \varphi)$ is a rational function of $\sin \varphi$ and $\cos \varphi$.

Let $z = e^{i\varphi}$. Then $\sin \varphi = \frac{z - z^{-1}}{2i}$, $\cos \varphi = \frac{z + z^{-1}}{2}$ and $dz = i e^{i\varphi} d\varphi$ or $d\varphi = \frac{dz}{iz}$.

The given integral is equivalent to $\oint_C F(z) dz$ where C is the unit circle with center at the origin [Fig.28].

3. $\int_{-\infty}^{+\infty} F(x) \begin{cases} \cos mx \\ \sin mx \end{cases} dx$, where $F(x)$ is a rational function.

Here, we consider $\oint_C F(z) e^{imz} dz$, where C is the same contour as that in Type 1.

Example 33 Evaluate $\int_0^{+\infty} \frac{dx}{1+x^6}$.

Solution

Consider $\oint_C \frac{dz}{1+z^6}$, where C is the closed contour of Fig.25 consisting of the line from $-R$

to $+R$ and the semicircle Γ , traversed in the positive (counterclockwise) sense.

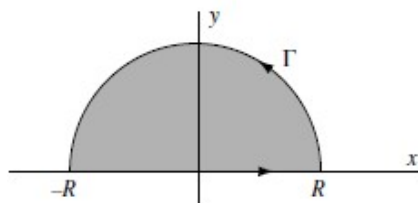

Fig.25

Since $z^6 + 1 = 0$ when $z_1 = e^{\frac{\pi i}{6}}, z_2 = e^{\frac{3\pi i}{6}}, z_3 = e^{\frac{5\pi i}{6}}, z_4 = e^{\frac{7\pi i}{6}}, z_5 = e^{\frac{9\pi i}{6}}, z_6 = e^{\frac{11\pi i}{6}}$,

these are simple poles of $\frac{1}{z^6 + 1}$. Only the poles $z_1 = e^{\frac{\pi i}{6}}, z_2 = e^{\frac{3\pi i}{6}}, z_3 = e^{\frac{5\pi i}{6}}$ lie within C .

Then, using L'Hospital's rule,

$$\text{Res}_{z=e^{\frac{\pi i}{6}}} f(z) = \lim_{z \rightarrow e^{\frac{\pi i}{6}}} \left(z - e^{\frac{\pi i}{6}} \right) f(z) = \lim_{z \rightarrow e^{\frac{\pi i}{6}}} \left(z - e^{\frac{\pi i}{6}} \right) \frac{1}{z^6 + 1} = \lim_{z \rightarrow e^{\frac{\pi i}{6}}} \frac{1}{6z^5} = \frac{1}{6} e^{-\frac{5\pi i}{6}},$$

$$\text{Res}_{z=e^{\frac{3\pi i}{6}}} f(z) = \lim_{z \rightarrow e^{\frac{3\pi i}{6}}} \left(z - e^{\frac{3\pi i}{6}} \right) f(z) = \lim_{z \rightarrow e^{\frac{3\pi i}{6}}} \left(z - e^{\frac{3\pi i}{6}} \right) \frac{1}{z^6 + 1} = \lim_{z \rightarrow e^{\frac{3\pi i}{6}}} \frac{1}{6z^5} = \frac{1}{6} e^{-\frac{5\pi i}{2}},$$

$$\text{Res}_{z=e^{\frac{5\pi i}{6}}} f(z) = \lim_{z \rightarrow e^{\frac{5\pi i}{6}}} \left(z - e^{\frac{5\pi i}{6}} \right) f(z) = \lim_{z \rightarrow e^{\frac{5\pi i}{6}}} \left(z - e^{\frac{5\pi i}{6}} \right) \frac{1}{z^6 + 1} = \lim_{z \rightarrow e^{\frac{5\pi i}{6}}} \frac{1}{6z^5} = \frac{1}{6} e^{-\frac{25\pi i}{6}}.$$

Thus,

$$\oint_C \frac{dz}{1+z^6} = 2\pi i \left(\frac{1}{6} e^{-\frac{5\pi i}{6}} + \frac{1}{6} e^{-\frac{5\pi i}{2}} + \frac{1}{6} e^{-\frac{25\pi i}{6}} \right) = \frac{2\pi}{3}$$

that is,

$$\int_{-R}^R \frac{dx}{1+x^6} + \int_{\Gamma} \frac{dz}{z^6 + 1} = \frac{2\pi}{3}.$$

Taking the limit of both sides as $R \rightarrow \infty$

$$\lim_{R \rightarrow \infty} \int_{-R}^R \frac{dx}{1+x^6} = \int_{-\infty}^{+\infty} \frac{dx}{1+x^6} = \frac{2\pi}{3}.$$

Since

$$\int_{-\infty}^{+\infty} \frac{dx}{1+x^6} = 2 \int_0^{+\infty} \frac{dx}{1+x^6}.$$

the required integral has the value $\frac{\pi}{3}$.

Exercise Set 8

In Exercises 1 to 18 evaluate

$$1. \oint_{|z|=2} \frac{e^z}{z^2(z+1)} dz.$$

$$2. \oint_{|z-i|=1} \frac{e^z}{z^4 + 2z^2 + 1} dz.$$

$$3. \oint_{|z|=3} \frac{\sin z dz}{z^2(z^2-4)}.$$

$$4. \oint_{|z|=2} \frac{e^z dz}{z^2(z^2-9)}.$$

$$5. \oint_{|z-i|=3} \frac{e^{z^2}-1}{z^3-iz^2} dz.$$

$$6. \oint_{|z-1|=2} \frac{\cos \frac{z}{2}}{z^2-4} dz.$$

$$7. \int_0^{2\pi} \frac{dt}{13-5\cos t}.$$

$$8. \int_0^{2\pi} \frac{dt}{(3+\sin t)^3}.$$

$$9. \int_0^{2\pi} \frac{dt}{(5-4\cos t)^2}.$$

$$10. \int_{-\infty}^{\infty} \frac{x^2+2}{x^4+x^2+12} dx.$$

$$11. \int_{-\infty}^{\infty} \frac{x-1}{(x^2+4)^2} dx.$$

$$12. \int_{-\infty}^{\infty} \frac{dx}{(x^2+1)^3}.$$

$$13. \int_{-\infty}^{\infty} \frac{x e^{ix}}{x^2-8x+20} dx.$$

$$14. \int_{-\infty}^{\infty} \frac{x^2 e^{2ix}}{x^4+10x^2+9} dx.$$

$$15. \int_{-\infty}^{\infty} \frac{dx}{(x^2+4)^2(x^2+16)}.$$

$$16. \int_{-\infty}^{\infty} \frac{dx}{(x^2+1)^2(x^2+4)}.$$

$$17. \int_{-\infty}^{\infty} \frac{x e^{2ix}}{x^2-10x+26} dx.$$

$$18. \int_{-\infty}^{\infty} \frac{x^2 e^{2ix}}{x^4+13x^2+36} dx.$$

Literature

1 Murray R. Spiegel, Seymour Lipschutz, John J. Schiller Complex Variables with an introduction to conformal mapping and its applications / The McGraw-Hill Companies. 2009. pp.374.

2 Lars v. Ahlfors Complex Analysis An Introduction to the Theory of Analytic Functions of the One Complex Variable / The McGraw-Hill Companies. 1979. pp.331.

Contents

1	Complex Number System.....	3
1.1	The Complex Number System. Fundamental Operations with Complex Numbers....	3
1.2	Graphical Representation of Complex Numbers. Polar Form of Complex Numbers..	4
1.3	Euler's Formula. Polynomial Equations. Roots of Complex Numbers.....	5
	Exercise Set 1.....	9
2	Functions, Limits, and Continuity.....	10
2.1	Functions of Complex Variable.....	10
2.2	The Elementary Functions.....	11
2.3	Limits. Continuity.....	14
	Exercise Set 2.....	15
3	Complex Differentiation and the Cauchy–Riemann Equations.....	16
3.1	Derivatives. Analytic Functions. Cauchy–Riemann Equations. Geometric Interpretation of the Derivative.....	16
	Exercise Set 3.....	19
3.2	Differentials. Rules for Differentiation. Derivatives of Elementary Functions.....	19
3.3	Higher Order Derivatives. L'Hospital's Rule. Singular Points.....	20
	Exercise Set 4.....	23
4	Complex Integration and Cauchy's Theorem. Cauchy's Integral Formulas.....	23
4.1	Complex Line Integrals.....	23
	Exercise Set 5.....	29
4.2	Cauchy's Integral Formulas.....	30
	Exercise Set 6.....	32
5	Infinite Series Taylor's and Laurent's Series. The Residue Theorem Evaluation of Integrals.....	32
5.1	Series of Functions. Power Series. Taylor's Theorem.....	32
5.2	Laurent's Theorem. Classification of Singularities.....	36
	Exercise Set 7.....	40
5.3	Residues. Calculation of Residues. The Residue Theorem. Evaluation of Definite Integrals.....	41
	Exercise Set 8.....	45
	Literature.....	46

УЧЕБНОЕ ИЗДАНИЕ

Составители:

Гладкий Иван Иванович
Дворниченко Александр Валерьевич
Каримова Татьяна Ивановна
Лебедь Светлана Федоровна
Шишко Татьяна Витальевна

ELEMENTS OF THEORY OF ANALYTIC FUNCTIONS OF ONE COMPLEX VARIABLE

учебно-методическая разработка на английском языке
по дисциплине «Математика»

Ответственный за выпуск: Дворниченко А.В.

Редактор: Боровикова Е.А.

Компьютерная вёрстка: Гладкий И.И.

Корректор: Никитчик Е.В.

Подписано к печати 13.03.2015 г. Формат 60x84 ¹/₁₆. Гарнитура Arial Narrow.
Бумага «Performer». Усл. п. л. 2,79. Уч. изд. 3,0. Заказ № . Тираж 40 экз.
Отпечатано на ризографе учреждения образования «Брестский государственный
технический университет». 224017, г. Брест, ул. Московская, 267.